

GATEWAY TO THE SAVAGE FRONTIER
**ADVENTURER'S
JOURNAL**



STRATEGIC SIMULATIONS, INC.®

CREDITS

Game Creation:	Beyond Software, Inc.
System Creation:	SSI Special Projects Group
Scenario Design:	Don Daglow
IBM Programming and Technical Design:	Cathryn Mataga
Amiga Programming:	Linwood Taylor
C-64 Programming:	Mark Manyen
Other C-64 Programming:	Westwood Associates
Amiga Programming Support and IBM Music Driver:	MicroMagic, Inc.
IBM Sound Effects Driver:	John Ratcliffe
Music Production:	Linwood Taylor
Encounter Authors:	Don Daglow: Yartar, Nesme, Everlund, Silverymoon, Kraken Outpost, Neverwinter, Port LLast, Luskan, Tuern, Purple Rocks, Kraken HQ, Secomber, Star Mounts and Sundabar Linwood Taylor: LLoekh, Loudwater Mark Buchignani: Ascore Cathryn Mataga: Gundarlun
Art Director:	David Bunnett
Artists:	David Bunnett: Walls, Monsters, Small and Large Graphics Sergio Lobato: Walls, Monsters, Small and Large Graphics Arturo Sinclair: Wilderness Map
Additional Art:	SSI Special Projects Group
Journal Entries:	Don Daglow
Game Development:	George MacDonald, Rick White
Documentation:	Richard Wilson
Playtest Manager:	Larry Webber
Playtesters:	Alan Marenco, John Kirk, Cyrus Harris, Jeff Shotwell, Glen Cureton, James Young, Phil Alne, Mike Baljiadia, Jason Ray, Eduardo Trillo, André Vrignaud, Dennis Zahina
Special IBM Testing:	Top Star Computer Services, Inc.
Art, Graphic Design & DTP:	LOUIS SAEKOW DESIGN: Peter Gascoyne
Pre-press Production:	LOUIS SAEKOW DESIGN: Kirk Nichols & Ray Garcia
Printing:	American Lithographers, Inc.

TABLE OF CONTENTS

Introduction: First Night in Yartar	1
Important Features of the Savage Frontier	2
Towns and Cities	2
Forests	3
The Trollmoors	3
The Great Desert	3
Islands	3
Characters and Parties	4
Player Races	4
Ability Scores	4
Character Classes	5
Alignment	6
Other Attributes	7
Building a Successful Party	8
Combat	9
Combat Map	9
Initiative	9
Computer Control	9
Combat Ability	9
Attacking	10
Combat Movement	10
Combat Strategies	11
After Combat	11
Magic	12
Magic-Users	12
Clerics	12
Tips on Magic	12
Magic Treasures	13
Creatures of the Savage Frontier	14
Spell Descriptions	16
Journal Entries	20
Tables	38

INTRODUCTION:

The First Night in Yartar

"We had thought this was going to be a routine mission, guarding a caravan of mithril travelling from Citadel Abdar in the far north. But no sooner did we sign on to provide protection than the dwarves' King Harbromm himself called us to the top of the tallest tower in the fortress.

"Now, Harbromm, he talks through his great whiskers and it sounds like a bellows blowing, but this particular morning he didn't have to say much to get our attention.

"He pointed to the northeast, and we looked towards a brown cloud floating above one of the mountain valleys. 'Do you see that? It is dust,' he said, his voice rising. 'It is the dust of tens of thousands of the Ice Mountain Orcs as they march from their caves towards the cities of the south.'

"'But that always happens this time of year,' someone replied. 'Orc raiding parties are always attacking Sundabar or ambushing caravans from Silverymoon.'

"The old dwarf nodded. 'Aye, that's true. But turn your eyes to that dark cloud once more. Is that the dust of a thousand raiders? I think not. Two thousand? By no means. If we are lucky, perhaps only two thousand times ten.'

"'Guard well this caravan, adventurers,' he told us. 'Evil is again awakened in the Realms, and its eyes and hands — and daggers — will be all around you.'

"Well, after that speech you can imagine how worried we all were. Every step of the way we scanned the horizon, looking for those dark brown clouds. We didn't see any, but we sure heard a lot of

stories. Seems like everyone in the northern Realms knows someone who's seen at least a dozen trolls or a hundred orcs skulking across their fields."

A burly fighter by the bar called out, "So you came all this way with such a fine-looking sword and never had a chance to quench it with orcish blood?" His voice dripping with sarcasm, he mimicked a dancer tiptoeing across a stage. "Perhaps you didn't want a fight. Perhaps it's just a child's toy with a fine golden handle attached to it for show!"

Before his words had even crossed the room the sword in question was drawn, its gleaming blade flashing even in the dim light of the tavern. The room went silent as they waited to see if we'd attack the blustering fool. After a moment of hesitation the sword was sheathed again. "This sword is saved for orcish blood," we called back to the drunken fighter. "We do not care to soil it with yours."

The man looked at us, thought for a minute, realized he had been insulted and started to cross the room. Hesitating, he looked around. To his surprise, none of his companions were crossing with him. He started to admonish them, call them to battle, but the words were stilled in his throat.

A tall, thin, black-caped man was sitting in the corner, and he shook his head one time. The drunken fighter dropped his eyes to the floor, muttered something, then turned and left the tavern. Several others followed.

There was another moment of awkward silence. The man in the corner nodded, and the waitress appeared with a heaping tray, crying "More for everyone, it's on the house!"

We all surged forward for our share, and the rest of the evening was full of great fun and storytelling.

IMPORTANT FEATURES OF THE SAVAGE FRONTIER

GATEWAY TO THE SAVAGE FRONTIER covers a wide geographical area, ranging from the coast of the Trackless Sea in the west to the edge of the Great Desert in the east. Most of the population of this area lives in the towns and cities, with farming communities clustered around the built-up areas.

Towns and Cities

Yartar is where you start the game and will serve as a convenient home base. A trading town located on the River Surbrin just north of where it joins the Dessarin, it lies at the junction of the river and the Evermoor Way, one of the two primary east-west trading routes in the region.

Ascore is no longer a city at all. Once a thriving dwarven seaport when the Great Desert was the Narrow Sea, it shrank to nothingness when the waters receded and the land dried and turned to dust. Travel here is very perilous and not recommended for any but the most experienced parties.

Everlund is located on the overland route between Silverymoon and Yartar and prospers as a trading town due to its location.

Llorck lies on the ancient trade routes that follow the long path around the southern edge of the Great Desert. Long a dwarven stronghold, the town has recently come under the rule of a human magic-user, Lord Geildarr. The stories of what's going on in this mining and trading center are jumbled and contradictory, but none of them are good.

Loudwater, with a population that includes many half-elves, lies in the southern part of the region. Its fields are so green and its walls so overgrown with vines that it almost seems to be part of the High Forest, which lies just to the north.

Luskan, located on the northwest coast, is a city ruled by Northman sea captains who retired here years ago. There are stories that its leaders are actually former pirates who continue to sponsor attacks on shipping and that other evil forces have allied with them to enforce their rule in

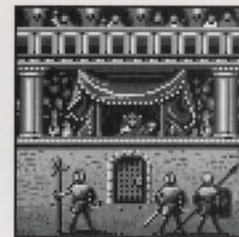

“ We were led into the great arena before a screaming crowd. Their chorus of boos made clear which side they were on. ”

the city. Luskan is hostile to many of the other cities in the region — especially Neverwinter — and rumors of impending war surface periodically.

Nesme, on the River Surbrin at the western edge of the Trollmoors, is a trading town. Its old wooden stockade has seen more than one troll assault, and Nesme riders patrol to keep the area near the city clear of monsters.

Neverwinter lies to the west of Neverwinter Wood, and is famed for its indoor gardens and fine craftsmen who can even craft magical weapons. Its people are friendly to outsiders. The Neverwinter River, which runs through the area, is warm even in the snows of winter, and no one knows why. A magic shop — a rarity in the Savage Frontier — is also located here.

Port Llast is a small town on the central coast. Once a major seaport, the centuries have seen its decline until now stonemasonry is its most important trade.

Secomber, a quiet town in the southwest, is said to be home to an eccentric magic-user who continually creates clever new items and devices.

Silverymoon, in the northeast area of the region, is a large city known for its magicians. An invisible magic bridge spans the River Rauvin as it flows through the city. A magic college and items shop are located here as well.



“ There are those who say that magical weapons can be crafted in Neverwinter... for a price! ”

Sundabar, in the far northeastern area, is a former dwarven stronghold now rebuilt by humans into one of the largest towns in the northern Realms. It trades with dwarven miners to the north and with Silverymoon and Everlund to the west.

Forests

The **High Forest** dominates the center of the region. Although its vast expanse is known to harbor peaceful as well as hostile creatures, traversing it is dangerous and should not be attempted until your party has grown very strong.

Neverwinter Wood is likewise dangerous for travel. Local legend has it that even raiding orc parties choose to go around the Wood rather than through it.

The Trollmoors

The **Trollmoors**, located in the north central area of the region, are a dangerous expanse of low, windswept, blighted hills. As their name indicates, the local inhabitants are both unfriendly and dangerous.

The Great Desert

The **Great Desert of Anauroch** is a hostile area filled with vile monsters and weather that swings from bitter heat to biting cold in moments and is a place to avoid at all costs.

Islands

Gundarlun, and its capitol **Gundborg**, are inhabited by Northmen. The island lies almost due west of Neverwinter, two days away by boat. Their status as an important shipping and resupply port, however, has made the inhabitants far more tolerant of other peoples, and you will usually find a warm welcome when you visit.

The **Purple Rocks** are a group of small, rocky, islands to the west of Gundarlun. Little is known about them, but outsiders are not welcome there.

Tuern is also inhabited by Northmen. Its capitol of **Uttersea** is built into the side of a collapsed, extinct volcano. Other volcanos on the island still spew out molten lava. Its people tolerate outsiders but are by no means glad to see them. There are reports of a recent meteorite strike on Tuern, and meteorite ore is a key ingredient in some kinds of magical weapons.

CHARACTERS AND PARTIES

You must have a party of adventurer Player Characters (PCs) to play *GATEWAY TO THE SAVAGE FRONTIER*. For each character you must choose the following: a Race, a Class, and an Alignment. After you select these, the computer generates a set of Ability Scores that define your new character's natural strengths and weakness. To build a party you must make a mix of characters that have the range of skill needed for success, and then band them together.

Player Races

There are six races from which you may construct player characters, each with different talents and limitations. Tables beginning on page 38 summarize the racial class limitations and ability score modifiers. The following describes each race and tells which classes are open to them.

Dwarves are a cunning race of sturdy workers and craftsmen. They are especially resistant to magic and poison. Dwarves receive bonuses when attacking man-sized giant-class creatures and are adept at dodging the attacks of larger giant-class creatures. Dwarves can be fighters, thieves, and fighter/thieves.

Elves are a tall, long-lived race. They are nearly immune to sleep and charm spells and are adept at finding hidden objects such as secret doors. Elves also receive bonuses when attacking with swords and bows, although they cannot be raised from the dead. Elves can be fighters, magic-users, thieves, fighter/magic-users, fighter/thieves, magic-user/thieves, and fighter/magic-user/thieves.

Half-Elves are hybrids with many of the virtues of both humans and elves. Like their elf ancestors, they are resistant to sleep and charm spells and are adept at

finding hidden objects. Half-elves can be fighters, magic-users, clerics, thieves, rangers, cleric/fighters, cleric/rangers, cleric/magic-users, fighter/magic-users, fighter/thieves, magic-user/thieves, cleric/fighter/magic-users, or fighter/magic-user/thieves.

Gnomes are shorter and slimmer than their dwarf cousins. They are especially resistant to magic. Gnomes receive bonuses when attacking man-sized giant-class creatures and are adept at dodging the attacks of larger giant-class creatures. Gnomes can be fighters, thieves, and fighter/thieves.

Halfings are about half the size of a human, hence their name. They are especially resistant to magic and poison. They can be fighters, thieves, and fighter/thieves.

Humans are the most common player-race in the Forgotten Realms. They suffer no level racial limitations or ability score modifiers. Humans do have the disability of shorter life-spans than the other races. This may be a problem if they are subjected to many Haste spells, which age the target one year. They can be fighters, magic-users, clerics, thieves, rangers, paladins, and dual-class characters.

Ability Scores

Every character has six randomly generated ability scores as explained below. These scores fall within a range determined by the race and class of the character. The base values range from 3 (low) to 18 (high) and there are tables of limitations, modifiers, and bonuses starting on page 38.

Depending on the character class, one or more of these abilities will be a Prime Requisite. A prime requisite is an ability especially valuable to a given class. For

example, strength is key for fighters and wisdom for clerics. Most characters receive bonus experience points when their prime requisite scores are 16 or greater.

Non-human characters may have modifiers to the basic ability scores to reflect differences between the races. Dwarves for instance, get a +1 constitution bonus and may have a maximum constitution of 19 instead of 18. When a character is generated, all racial modifiers are calculated automatically.

Strength (STR) is the measure of a character's physical power, muscle mass, and stamina. Fighter-type characters may have exceptional strengths greater than 18 that are indicated by a percent value (01, 02, 03 . . . 98, 99, 00) following the base strength. High strength increases a character's combat ability with melee weapons such as swords or maces. Strength also determines how much a character can carry without becoming encumbered and slowed in combat.

Intelligence (INT) is the measure of how well a character can learn.

Wisdom (WIS) is the measure of a character's ability to understand the ways of the world and to interact with the world. Clerics receive bonus spells for high wisdom.

Dexterity (DEX) is the measure of a character's manual dexterity and agility. Thieves especially benefit from high dexterity. Dexterity affects how well a character can use ranged weapons (bows, darts, etc.), when he moves in a combat round, and how difficult he is to hit in combat.

Constitution (CON) is the measure of a character's overall health. Characters

receive one extra hit point if their constitution is 15 or two points if it is 16. Fighter-types (fighters, rangers, and paladins) receive additional bonuses for constitutions of 17 or 18. A character's constitution also determines the maximum number of times that character can be raised from the dead and the chance of a resurrection attempt being successful. Every time a character is successfully resurrected, 1 point of constitution is lost.

Charisma (CHA) is the measure of how others react to a character.

Character Classes

A character must belong to at least one character class. Non-human characters can have more than one class at the same time. Multi-class characters have more playing options, but increase in level slower because experience is divided evenly among all classes.

Clerics have spells bestowed on them by their deity and can fight wearing armor and using crushing (no edged or pointed) weapons. Clerics must memorize their spells just as magic-users, but they do not use spell books. When clerics gain a new spell level, they can automatically use any of the available spells for the new level. The prime requisite for clerics is wisdom.

Fighters can fight with any armor or weapons, but they cannot cast magic spells. The prime requisite for fighters is strength.

Rangers can fight with any armor or weapons. They do additional damage when fighting giant-class creatures, but must be of good alignment and have ability scores of at least 13 in strength and intelligence and at least 14 in wisdom and constitution. The prime requisites for rangers are strength, intelligence, and wisdom.

Paladins can fight with any armor or weapons. They are resistant to spells and poison, and can turn undead creatures as if they were a cleric two levels below their current level. Paladins are also always surrounded by the equivalent of a Protection from Evil spell. A paladin may heal two hit points of damage per level once a day and may Cure Disease once a week at 1st-5th levels and twice a week at 6th-8th levels. Paladins will not adventure with any evil characters. Paladins must be of lawful good alignment and have ability scores of at least 9 in intelligence and wisdom, at least 12 in strength, at least 13 in wisdom, and at least 17 in charisma. The prime requisites for paladins are strength and wisdom.

Magic-Users have powerful spells, but can use no armor and few weapons. They can only memorize those spells available in their personal spell books or on scrolls. Magic-users may add entries to their spell books whenever they go up in level or find scrolls with spells they can scribe. The prime requisite for magic-users is intelligence.

Thieves can fight with swords and slings, but are limited to leather armor. In combat they do additional damage by 'back stabbing,' which is described in the Combat section. Thieves also have special skills for opening locks and removing traps. The prime requisite for thieves is dexterity.

Multi-class are non-human characters who belong to two or more classes at the same time. Multi-class characters' experience points are divided among each of the classes, even after they can no longer advance in one or more of those classes. Their hit points per level are averaged among the classes. Multi-class characters gain all the benefits of all their classes with regard to weapons and equipment.

Dual-class are human characters who had one class for the first part of their career, and then changed to a new class for the remainder. Once a character changes classes, he cannot advance in his old class. Dual-class characters do not gain hit points and cannot use the abilities of the old class while their new class level is less



“ The man had a crazed look. He had obviously been in the dungeon for a long, long time...” ”

than or equal to the old class level. Once the character's level in his new class is greater than his level in his old class, he gains hit points according to his new class and may use abilities from both classes. Human dual-class magic-users may not cast magic-user spells while they are wearing armor.

Alignment

Alignment is the philosophy a character lives by and can affect how NPCs and some magic items in the game react to a character. The possibilities range from believing strongly in society and altruism (lawful good) to being anarchistic and actively unpleasant (chaotic evil). Alignment is presented in two parts: World View and Ethics.

World View

Lawful indicates that the character values the structure and rules of society.

Neutral indicates that the character values both the individual and society.

Chaotic indicates that the character values the individual over society.



“The tower rose threateningly into the sky. Even from across the water, we could feel the evil within.”

Ethics

Good indicates that the character tries to act in a moral and upstanding manner.

Neutral indicates that the character leans towards “situational ethics,” evaluating each set of circumstances.

Evil indicates that the character acts without regard to others, or in an overtly malignant manner.

Other Attributes

Each character also has three important values that change as the game goes on: Hit Points, Experience Points and Levels.

Hit Points (HP) represent the amount of damage a character can take before he goes unconscious. A character’s maximum hit points are based on the hit dice for the

character’s class and level plus any adjustments for constitution.

Note:

Dice (d) is the term used to describe the range for a randomly generated number. Dice are referred to by the range they represent. A d6 has a range from 1 through 6, a d10 has a range from 1 through 10. **Hit dice** refers to the base range of hit points a character class may have. For example a 3rd level fighter has a base of 3 d10 hit dice, or 3-30 hit points.

A character gains a hit point bonus to each hit die if his constitution is over 14. When a character takes enough damage that his hit points reach 0, he is unconscious. If the character’s hit points drop to anything from -1 to -9, he will lose 1 hit point per turn from bleeding until he is bandaged or dies. If a character has -10 hit points or less, he is dead. When you view a character, his hit points (HP) on the screen will never be displayed as less than 0.

Experience Points (EXP) are a measure of what a character has learned while adventuring. Characters receive experience points for actions such as fighting monsters, finding treasures, and successfully completing quests. The computer keeps track of experience, and when characters earn enough they may advance in levels. See the Level Advancement Tables beginning on page 42 for experience requirements.

All characters start the game with 3,000 experience points. This means that single-class characters start at 2nd or 3rd level.

Levels are a measure of how much a character has advanced in his class.

When they have enough experience points, characters may go to a training hall and receive the training required to increase in level. Characters may only advance one level at a time. If a character has gained enough experience to go up two or more levels since the last time he has trained, he will go up one level, and lose all experience in excess of one point below the next level.

Example:

An 4th level thief enters a training hall with 20,521 experience points (enough for 6th level). He will leave as a 5th level thief with 20,000 experience points — one point below 6th level. Characters cannot train for new levels once they have reached their maximum levels allowed in *GATEWAY TO THE SAVAGE FRONTIER*.

Building a Successful Party

Forming a strong and adaptable party is a key to success in *GATEWAY TO THE SAVAGE FRONTIER*. Up to six Player Characters (PCs) may be in a party — A party with fewer is less powerful and more likely to be eliminated by opponents.

Include a variety of classes in a party to get a good mix of skills. Here are two sample parties as examples:

Sample Party 1 — Single Class Characters:

- 1 Elf Magic-user
- 1 Human Paladin
- 1 Dwarf Fighter/Thief
- 1 Half-elf Ranger
- 2 Human Clerics

This party is balanced for combat, and will advance quickly because most characters are a single class. The magic-user can

cast offensive spells and use wands. The paladin has the benefit of Protection from Evil in a 10’ radius. All characters in range of the effect get an AC improvement of two. The dwarf fighter/thief offers the advantages of a thief (lockpicking and disarming traps) with the better armor and hit points of a fighter. Rangers do extra damage against giant type creatures and start with extra hit points. Clerics are absolutely essential for valuable healing spells.

Sample Party 2 — Multi-class Characters:

- 2 Half-elf Cleric/Magic-users
- 2 Elf Fighter/Magic-users
- 1 Dwarf Fighter/Thief
- 1 Human Paladin

This party is much more flexible than the first, but will advance more slowly because of the multi-class characters.

Outfitting the Party

The following are some suggestions for outfitting your party in Yartar:

- **Fighter Classes:** Buy shields, splint mail, broad swords, long bows, and arrows.
- **Magic-users:** Buy quarterstaves and darts.
- **Clerics:** Buy splint mail, shields, staff slings, and maces.
- **Thieves:** Buy leather armor, short swords, short bows, and arrows.

Preparation Tips

Once the party has been outfitted, Encamp at an inn and ready your weapons, armor, and shields. Then have all spellcasters memorize spells. Finally, save the game before continuing.

COMBAT

Adventurers must battle their way through many dangerous foes to complete the adventure. The following sections offer some more information and tips for combat.

Combat Map

Battle takes place on a tactical combat map that is a detailed view of the terrain that the party was in when the combat began. This map is set up with an invisible square grid.

Initiative

Each round of combat is divided into 10 segments, and every character and foe acts on a specific segment based on Initiative. Initiative is generated at the start of each combat round, and is modified by dexterity and random factors such as surprise. Casting spells may take extra time to perform, so often a spell-caster will begin a spell on his segment but it will not go off until a little later.

Computer Control

In combat you control the actions of PCs. The computer controls the actions of monsters, NPCs, and PCs set to computer control with the QUICK command.

Combat Ability

Each character's ability in combat is defined by AC, THACØ, and Damage.

AC

A character or monster's difficulty to be hit is represented by armor class (AC). The lower the AC, the harder the target is to hit. AC is based on armor and a dexterity bonus. Some magic items, such as some bracers, also help improve AC.

THACØ

Ability to hit enemies in melee or with missile fire is represented by THACØ. THACØ stands for To Hit Armor Class Ø. This is the number a character must 'roll' equal to or greater than to do damage on a target with an AC of Ø. The lower the THACØ, the better the chance to hit the target.

Note:

the generation of a random number is often referred to as a 'roll.' In determining if an attack hit, the number generated is from 1 through 20.

An attack is successful if the random number is greater than or equal to the attacker's THACØ minus the target's AC. THACØ may be modified by things like range, attacking from the rear, magic weapons, and magic spells.

Example:

A fighter with a THACØ of 16 attacking a monster with an AC of 3 would need to roll: (THACØ 16) - (AC 3) = 13+

But to hit a monster with an AC of -2 he would need to roll: (THACØ 16) - (AC -2) = 18+

Damage

Damage is the range of hit points loss the attacker inflicts and is based on the attacker's strength, weapon type, and any magic bonuses the weapon has. The base damage for each weapon is summarized in the Weapons Table on page 40.

Some monsters take only partial or no damage from certain weapon types. Skeletons, for example, take only half damage from sharp or edged weapons, while some other monsters can only be damaged by magical weapons.

Attacking

There are two basic types of combat: Melee and Ranged (or Missile). The following describes each type and other rules governing combat.

Melee Combat

Melee combat is face-to-face fighting with weapons such as swords and maces. Only when using melee weapons can characters receive strength bonuses. During melee combat fighters can sometimes overpower several small foes, and thieves have opportunities to back stab.

Ranged Combat

Ranged combat is firing at distant enemies with weapons such as bows or darts. A character with a missile weapon (bow, sling, etc.) may not attack when adjacent to an enemy. Two arrows or three darts can be fired per turn. When opponents get too close for ranged combat, characters must switch to melee weapons.

Multiple Attacks (Sweeping)

When fighting small creatures, fighter-types (fighters, rangers, and paladins) may 'sweep' through several weak opponents in one combat round. When a character attacks a weak target, he automatically sweeps all of the available weak opponents.

Back Stabbing

A thief back stabs if he attacks a target from exactly opposite the first character to attack the target. The thief may not back stab if he has readied armor heavier than leather. A back stab has a better chance of hitting the defender and does additional damage.

Saving Throws

Attacks such as poison or spells do not automatically have their full effect on a target. Victims may get a Saving Throw to avoid some or all of the effect. If the saving throw is successful, generally the target suffers either no effect or only half-damage. As characters gain levels, saving throws improve.

Note:

Some monsters have magic resistance which decreases their chance of being affected by spells.



“ The pitiful figure before us gave witness to the evils our enemies visit upon the helpless. ”

Combat Movement

The number of squares a character can move is affected by carried weight, character strength, and the kind of readied armor. A character's movement range is displayed on the View Screen and during the character's segment in combat.

Combat movement is important for both closing quickly with opponents (and stopping missile fire) and fleeing from battles that are too tough.

Running Away

A character may flee from the battlefield if he moves faster than all enemies, but not if he moves slower than any enemies. A character has a 50% chance to move off

the battlefield if he moves as fast as the fastest foe. Exception: if a character can reach the edge of the combat map without any of his opponents being able to see him, he may then flee successfully even though he is slower than his opponents.

Returning to the Party

A character that moves off the battlefield returns to the party after the fight is over. If all active characters flee combat, any dead or unconscious characters are lost. If a whole party flees, no one receives any experience points for monsters killed before retreating.

Combat Strategies

To succeed in combat, a skilled player deploys his party well, casts effective spells before and during combat, maneuvers his characters into advantageous positions, and attacks using his most powerful characters and weapons.

Deploying the Party

When a battle begins, your party is automatically positioned based on the order list of the characters. Characters near the top of the order will be in the front lines and vulnerable to attack. To change the starting deployment, change the party order from the Alter Menu while encamped. Shift the heavily armored fighters up the list and the vulnerable magic-users and thieves towards the bottom. Party order cannot be changed while in combat, although characters are free to move.

Your party may be placed in a bad position at the start of a battle. Get an idea of the situation, and move characters into position. Sometimes the best strategy is offensive: charging with fighters to close ground and stop enemy missile fire. Other times the best strategy is defensive: moving your characters to anchor their flanks on an obstacle such as a wall or tree.

Setting up behind a doorway that your enemies have to move through also makes for a very strong defensive position. Always keep magic-users and missile weapons safe behind the front line.

Wounded Characters

Characters who are seriously injured should be moved out of the front lines if possible. Remember: if you move away from an adjacent enemy, he gets a free attack at your back and has an improved chance to hit.

Stopping Ranged Attacks

Missile weapons cannot be fired if there is an adjacent opponent. To stop enemy missile fire, move someone next to the opponent. If you want to fire missiles, keep away from the enemy.

Exploiting Enemies' Weaknesses

Exploit your opponents' weaknesses by directing attacks against helpless, wounded, or isolated foes. Concentrate your attacks to eliminate one opponent rather than injure many (Exception: enemy spell casters). A foe with one hit point remaining attacks as powerfully as an uninjured one.

Spell casters cannot fire spells after they have taken damage in a round, and they lose any spells they are in the process of casting when they are hit. Try to keep enemy spell casters under attack every round while protecting your own.

After Combat

If one or more characters survive on the battlefield at the end of combat, the bodies of unconscious or dead party members stay with the party. If the entire party flees from combat, all unconscious and dead party members are permanently lost. If ALL the party members are slain, go back to your last Saved Game and try again from that point.

MAGIC

Magic is essential to the survival of the party. Magic-users cast many powerful offensive and defensive spells. Clerics cast healing spells to revive wounded characters as well as both defensive and offensive spells. A spell can exist in one of four forms: in a character's memory, in a character's spell book, in a scroll, or in a wand. A spell-caster with a memorized spell can cast it using the CAST command. Spells are memorized during rest while encamped. Spells in scrolls or wands are cast with the USE command.

Memorizing a spell takes 15 minutes of game time per spell level, plus a preparation period of four hours plus an additional two hours for 3rd level spells. For example, 1st and 2nd level spells take a minimum preparation of four hours, while 3rd level spells take six hours.

Example:

To memorize two 1st level spells, one 2nd level spell, and one 3rd level spell would take: (6 hours preparation) + (2 * 15 min) + (1 * 30 min) + (1 * 45 min) = 7 hours 45 min

Magic-Users

When a magic-user trains for a new level, he selects a new spell to add to his spell book. A magic-user can also scribe spells from identified scrolls if he is of high enough level to cast them. A magic-user must cast a Read Magic spell or have a scroll identified in a shop before he can scribe (or cast) from it. The scroll disappears after it has been scribed or cast.

Clerics

Clerical magic requires no spell books. All clerical spells of the appropriate level are always available to a cleric, the character need only memorize them. Unlike magic-

users, clerics can cast spells from scrolls without any preparation, but clerical scrolls also disappear after being cast.



“ Strength wins many battles, but clear strategy, planning and preparation win many wars. ”

Tips on Magic

Both clerics and magic-users may cast spells which assist the party in combat. Preparatory spells, such as Bless or Strength, cast just before a battle can protect or strengthen characters. Combat spells can be cast to damage foes during combat. Healing spells can be cast either during or after combat to revive wounded comrades.

Spells should be rememorized as soon as possible after they are used. This is most likely to happen after combat. When in camp, have your spell-casters memorize spells and select REST to allow them to imprint the spells for later use. Selecting REST without choosing new spells has the spell-casters rememorize the spells they have cast since last resting.

Note:

Before resting, it is a good idea to save your game — especially after tough combats. Also, keep at least two separate saved games at all times and alternate between them. This will allow you to go back to a save before that last, fatal battle.

MAGICAL TREASURES

As you travel about and encounter the monsters and puzzles that stand between you and finishing your various quests, you will also find magical items to help you on your way. You can find magic items in a treasure by doing a Detect Magic spell using the DETECT command. To find out specifically what an item is, you must take it to a shop and have it identified.

Some magic items are in reality cursed and can do great harm. When a character readies a cursed item, a Remove Curse spell must be cast before the item can be dropped. Some magic items, such as wands or scrolls, may only be used by certain classes. Others may not work at all if certain other magic items are also in use.

Here are descriptions of some items that you may find. Remember: Some items are very rare, and you may not find all of them in your adventure.

Wands generally will cast a set number of a given spell (for example, 10 Fire Balls or 15 Magic Missiles). Only experimentation or paying to have them identified will tell what a wand does. The USE command allows a character to cast spells with a readied wand.

Potions may heal wounded characters, cause them to become hastened or invisible, or cause any number of other effects. The USE command allows a character to drink a readied potion.

Scrolls carry either clerical or magic-user spells. A magic-user may use SCRIBE to permanently transfer a scroll into his spell book if the spell is of a level that he can memorize. Magic-users and clerics can

both cast spells directly from scrolls with the USE command, even if they could not otherwise memorize the spells. Scrolls disappear after they have been used or scribed.

Enchanted Armor and Shields are created by skilled craftsmen and then enchanted with protective spells. The power of the magic on these items varies a great deal. Enchanted armor has the great advantage of offering improved protection with less encumbrance than the same type of mundane armor. To use these items, ready them from the Items Menu.

Enchanted Weapons come in many sizes, shapes, and potencies. Sometimes a weapon will add between one and four to your THACØ and damage. Other weapons may have other fantastic magical properties including extra bonuses against specific types of creatures. Once a magic weapon has been readied from the Items Menu, the character will have it for all combats.

Enchanted Adornments such as bracers, necklaces, periapts, and especially rings are favorite objects for magical enchantment. These items may have any number of magical properties. Some items will help your AC, others may fire Magic Missiles, or offer protection from fire-based attacks. Once one of these items has been readied from the Items Menu, a character automatically gains all effects. The exception to this rule is that certain magical necklaces require the USE command to work.

Enchanted Clothing can be such commonplace items of clothing as gauntlets or cloaks, but they are imbued with powerful enchantments. A wide variety of these items are known to exist. To use these items READY them from the Items Menu.

CREATURES OF THE SAVAGE FRONTIER

The denizens of these regions are many and varied. Here is a list of monsters you may encounter in your adventures. Some of these creatures are extremely rare, and you may never cross paths with them at all.

Ankhegs are burrowing monsters usually found in forests and farming areas. They resemble legged worms armed with wicked mandibles and sharply hooked limbs.

Basilisks are reptilian monsters whose very gaze can turn to stone any fleshy creature.

Boars (Wild) are a type of undomesticated swine armed with long tusks and mean dispositions.

Bugbears are giant, hairy cousins of goblins. They stand about 7' tall and are powerful warriors.

Displacer Beasts resemble a six-legged puma with two ebony tentacles growing from behind its shoulders. These beasts have the magical ability to displace their image about three feet from their actual body, making them especially tricky opponents.

Dragons are some of the most powerful and dangerous of the monsters a party can encounter. The older and larger the dragon, the more damage it can do and the harder it is to kill.

Efreet are genies from the elemental plane of Fire. These creatures are immune to all forms of fire, but can be hit by other magical attacks.

Ettin look like giant two-headed orcs. They have great strength and can wield two spiked clubs that inflict terrible damage in combat.

Frog (Giant) resemble their smaller kin in everything but size. Giant frogs have been known to swallow adventurers up whole.

Ghouls are undead creatures who feed on the flesh of the still living. Their attack can paralyze all races of characters except elves.

Giants vary greatly in power, intelligence, and tastes. The following is a list of the types of giants you are likely to encounter.



“ The man was obviously both powerful and dangerous. We had to decide, could we bargain with him or must we fight! ”

Fire Giants are brutal and ruthless warriors who resemble huge dwarves and have flaming red or orange hair and coal black skin.

Hill Giants are one of the smaller of the giant races, they are brutish hulks possessing low intelligence and tremendous strength.

Gnolls are large, evil, hyena-like humanoids that roam in loosely organized packs. They attack by overwhelming unwary victims with their numbers.

Goblins are small, nasty humanoids — they would be of little concern except for their great numbers.

Golems are magically created automata of great power. Golems can be constructed of flesh, clay, stone, or iron — all are dangerous.

Griffons are half-lion, half-eagle avian carnivores. Their favorite prey is horses and their distant kin (hippogriffs, pegasi, and unicorns).

Harpies are wicked avian humanoids that prey upon nearly all creatures but prefer the flesh of humans and demihumans.

Hell Hounds are other-planar creatures resembling wolves, but they can breathe fire and can detect invisible enemies.



“ With the whole of the Trackless Sea before us, our problems seemed somehow less important... ”

Hobgoblins are fierce humanoid warriors. They are intelligent, organized, and aggressive. Many times lesser humanoids will band together under a hobgoblin leader.

Lizards (Giant) are similar to their smaller kin in appearance and habit, although instead of eating insects, they prefer something more man-sized.

Lizard Men are savage reptilian humanoids. They generally attack in groups.

Manticores are a strange mix with lions' torso and legs, bats' wings, spike tipped tails, and human heads. The can fire volleys of spikes from their tails and have a great appetite for human flesh.

Margoyles are stony monsters that are immune to normal weapons and can attack many times with their sharp claws and spikes.

Medusae are hideous women-creatures with coiling masses of snakes for hair. They can turn a person to stone with their gaze.

Mummies are a powerful form of undead. They are driven by an unholy hatred of life.

Ogres are large, ugly, foul-tempered humanoids. Ogres generally attack with a spiked club.

Orcs are one of the most common, and disliked, of the demihuman races. They are aggressive and warlike.

Otyugh are scavengers armed with long tentacles that they use to scoop trash into their cavernous mouths.

Owlbears are thought to be a hybrid created by some long-forgotten wizard. They have the body of a large bear, and the head and slashing beak of a giant owl. Owlbears are vicious, evil tempered, and ravenous.

Salamanders are natives of the elemental plane of Fire and so are immune to all fire-based attacks. They are dangerous foes because of their evil nature and the fact that they can only be hit by magical weapons.

Scrags, also called river trolls, live in waterways and are related to trolls. They perhaps the most feared of all troll-kind.

Skeletal Warriors are a more powerful type of skeleton.

Skeletons are one of the weaker types of undead. These creatures are animated by evil wizards or clerics and are often used as guardians or warriors.

SPELL DESCRIPTIONS

First Level Cleric Spells

Bless improves the THACØ of friendly characters by 1. Bless cannot affect characters who are adjacent to monsters when the spell is cast. This is a good spell to cast before going into combat.

Curse impairs the THACØ of targets by 1. The target cannot be adjacent to a party character or NPC.

Cure Light Wounds heals 1-8 hit points (up to the target's normal maximum hit points).

Cause Light Wounds inflicts 1-8 hit points of damage on a target.

Detect Magic indicates which equipment or treasure items are magical. After casting the spell, view a character's items or Take treasure items — equipment or treasure preceded by an '*' or a '+' is magical.

Protection from Evil improves the AC and saving throws of the target by 2 against attackers of evil alignment.

Protection from Good improves the AC and saving throws of the target by 2 against attackers of good alignment.

Resist Cold halves the damage and improves saving throws vs. cold attacks by 3.

Second Level Cleric Spells

Find Traps indicates the presence of traps in the character's path.

Hold Person may paralyze targets of character types (human, dwarf, etc). You may aim a hold person spell at up to 3 targets (use the EXIT command to target fewer).

Slugs (Giant) are huge, omnivorous mutations of the common garden pest. They attack by biting and can spit a highly corrosive acid.

Snakes (Giant) are similar to their smaller kin and slay their prey with deadly venom. Neutralize Poison counters snake bites.

Spiders (Giant) are giant cousins of the small predator. They attack with a poisonous bite.

Squids (Large) are dangerous varieties of the smaller sea creature. They are known to attack travelers on the Trackless Sea.

Stirges are bird-like creatures that drink the blood of their victims. They are not terribly dangerous except in large numbers.

Tigers are carnivorous predators that are sometimes trained for combat.

Trolls are ravenous horrors found in almost all climates and locales. They attack with their dirty, clawed hands and must be killed quickly because they regenerate hit points.

Wyvern are distant relatives of dragons. They attack by biting and using the poisonous sting in their tail.

Zombies are mindless, animated undead controlled by evil wizards or clerics. While more dangerous than skeletons, they move very slowly and can be damaged by holy water.

Resist Fire halves the damage and improves saving throws vs. fire attacks by 3.

Silence 15' Radius must be cast on a character or a monster. That character or monster, and all adjacent to him, cannot cast spells for the duration of the spell.

Slow Poison revives a poisoned person for the duration of the spell.

Snake Charm paralyzes as many hit points of snakes as the cleric has hit points.

Spiritual Hammer creates a temporary magic hammer that is automatically Readed. It can strike at range and does normal hammer damage. Spiritual Hammers can hit monsters than may only be struck by magic weapons.

Third Level Cleric Spells

Bestow Curse reduces the target's THACØ and saving throws by 4.

Cause Blindness will blind one target. This can only be cured by a Cure Blindness spell

Cure Blindness removes the effect of the Cause Blindness spell.

Cause Disease infects the target with a debilitating ailment that saps strength and hit points.

Cure Disease removes the effects of disease caused by some monsters or caused by a Cause Disease spell.

Dispel Magic removes the effects of spells that do not have specific counter spells. This is a recuperation spell for any of the party that has been held, slowed, or made nauseous.

Prayer improves the THACØ and saving throws of friendly characters by 1 and reduces the THACØ and saving throw of monsters by 1. This is a good spell to cast before going into combat. Prayer is not cumulative with Bless or other Prayer spells.

Remove Curse removes the effects of a Bestow Curse spell and allows the target to unready cursed magic items.

First Level Magic-User Spells

Burning Hands causes 1 hit point of fire damage per level of the caster. There is no saving throw.

Charm Person changes the target's allegiance in a combat so that an opponent will fight for the caster's side. It only affects character types (human, dwarf, etc).

Detect Magic indicates which equipment or treasure items are magical. After casting the spell, view a character's items or Take treasure items — equipment or treasure preceded by an '*' or a '+' is magical.

Enlarge makes the target larger and stronger. The higher the caster's level, the larger and stronger the target gets.

Friends raises the caster's charisma by 2-8 points. It is best cast just before dealing with NPCs.

Magic Missile does 2-5 hit points per missile with no saving throw. A magic-user throws 1 missile for every 2 levels (1 at levels 1-2, 2 at levels 3-4, etc.) This spell damages any single target within its range unless the target is magic resistant or has certain magical protection. This spell casts instantaneously.

Protection from Evil improves the AC and saving throws of the target by 2 against attackers of evil alignment.

Read Magic allows a magic-user to ready a scroll and read it. This is identical to having a scroll identified in a shop. After casting Read Magic, a magic-user may scribe the spells from a scroll if appropriate for his class and level.

Shield negates enemy Magic Missile spells, improves the magic-user's saving throw, and may increase his AC.

Shocking Grasp does 1-8 hit points of electrical damage, +1 hit point per level of caster.

Sleep puts 1-16 targets (depending on the hit dice of the targets) to sleep with no saving throw. For example, up to sixteen 1 hit-die targets can be affected, while only one 4 hit-die target can be affected. Targets of 5 or more hit-dice are unaffected.

Second Level magic-user Spells

Detect Invisibility allows the target to spot invisible creatures.

Invisibility makes the target invisible. The THACØ of melee attacks against invisible targets is reduced by 4, and it is impossible to aim ranged attacks at them. Invisibility is dispelled when the target attacks or casts a spell.

Knock is used to open locks. It can be cast from the door-opening menu if the active character has a memorized knock spell.

Mirror Image creates 1-4 illusionary duplicates of the magic-user to draw off attacks. A duplicate disappears when it is attacked.

Ray of Enfeeblement reduces the target's strength by 25% + 2% per level of the caster.

Stinking Cloud paralyzes those in its area of effect for 2-5 rounds. If the target makes its saving throw, it is not paralyzed, but is nauseous and has its AC reduced for 2 rounds.

Strength raises the target's strength by 1-8 points depending on the class of the target.



“ There is a spell for every moment, but only the wisest will know when that moment has arrived. ”

Third Level Magic-User Spells

Blink protects the magic-user. The magic-user 'blinks out' after he acts each round. Although the magic-user may be physically attacked before he acts each round, he may not be physically attacked after he acts.

Dispel Magic removes the effects of spells that do not have specific counter spells. This is a recuperation spell for any of the party that has been held, slowed, or made nauseous.

Fireball is a magical explosion that does 1-6 hit points of damage per level of the caster to all targets within its area. If the target makes its saving throw, damage is halved. Fireball is a slow-casting spell and the spell's power demands that you target carefully. Use the CENTER command to determine who will be in the area of effect.

Haste doubles the target's movement and number of melee attacks per round. Haste has a short duration and you should wait until a fight is imminent to cast it. Warning: characters age one year each time a haste spell is cast on them.



“The sweet sound of the bubbling fountain should have been soothing, but the fountain's sinister visage kept us on our guard...”

Hold Person may paralyze targets of character types (human, dwarf, etc). You may aim a hold person spell at up to 4 targets (use the EXIT command to target fewer).

Invisibility, 10' Radius makes all targets adjacent to the caster invisible. The THACØ of melee attacks against invisible targets is reduced by 4 and it is impossible to aim ranged attacks at them. Use this spell to set up a battle line while your enemies seek you out. Characters lose invisibility if they do anything but move. Some monsters can see invisible creatures.

Lightning Bolt is a magical electrical attack that does 1-6 hit points of damage per level of the caster to each target along its path. If the target makes its saving throw, damage is halved. A lightning bolt is 4 or 8 squares long in a line away from the caster. For best results, send the bolt down a row of opponents. Lightning bolts also reflect off walls back toward the spell caster. Targets adjacent or close to a wall may be hit twice by the same bolt.

Protection from Evil, 10' Radius protects the target and all characters adjacent to the target. The spell improves the AC and saving throws of those it protects by 2 against attackers of evil alignment.

Protection from Good, 10' Radius protects the target and all characters adjacent to the target. The spell improves the AC and saving throws of those it protects by 2 against attackers of good alignment.

Protection from Normal Missiles makes the target immune to non-magical missiles.

Slow affects 1 target per level of caster and halves the target's movement and number of melee attacks per round. Slow can be used to negate a haste spell and only affects the side opposing the spell caster.

✧ JOURNAL ENTRIES ✧

□ JOURNAL ENTRY 1

A MIRROR MAP FROM THE HIGH WALL.

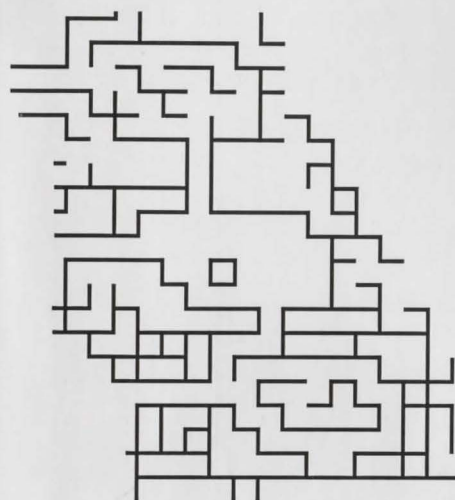

□ JOURNAL ENTRY 2

THE BLACK-ROBED RIDERS:

We backed up against the stone buttress at the end of the bridge, waiting to see what frightened everyone so badly.

A moment later they appeared, two riders in long, black robes with hoods that hid their faces. They came around the corner behind the Temple of Tymora, crossed the town square and pounded past us at the gallop. We turned and watched the guards stand back as the two raced through the gates and out of the city.

Slowly, the people in the square resumed their activities. Only now, they were all in a hurry to be somewhere else.

□ JOURNAL ENTRY 3

THE BOAT REPAIRMAN'S STORY:

"Well, funny you should ask. See these three boats over here? I found them just last week, one by one, washed up on the sand bar outside town.

"See those holes in the sides? I patched 'em up. There were arrows in them, lots of 'em. Plenty of blood on the floorboards, too, but I cleaned that all up.

"Haven't found any boats like that north of town, but I've been looking. Maybe going north on the river's safer than going east.

"I'll fix 'em up and sell 'em. It gives me the shivers thinking about what happened to the people that were in 'em, but... the people who buy 'em will never know. What they don't know won't hurt 'em."

□ JOURNAL ENTRY 4

THE FISHERMAN'S STORY:

The large fish market was almost empty, although the lingering smell of the place told of better days.

"How d'you like my sign!" the fisherman asked us, proudly. "Carved it m'self, y'know! 'Course, could do it better. Maybe now'd be a good time t'try. What with all the talk o' trolls and orcs and all, fishermen ain't goin' far up river. Ain't bringin' back much, neither.

"Good time for wood carvin'," he sighed sadly. "Bad time for sellin' fish."

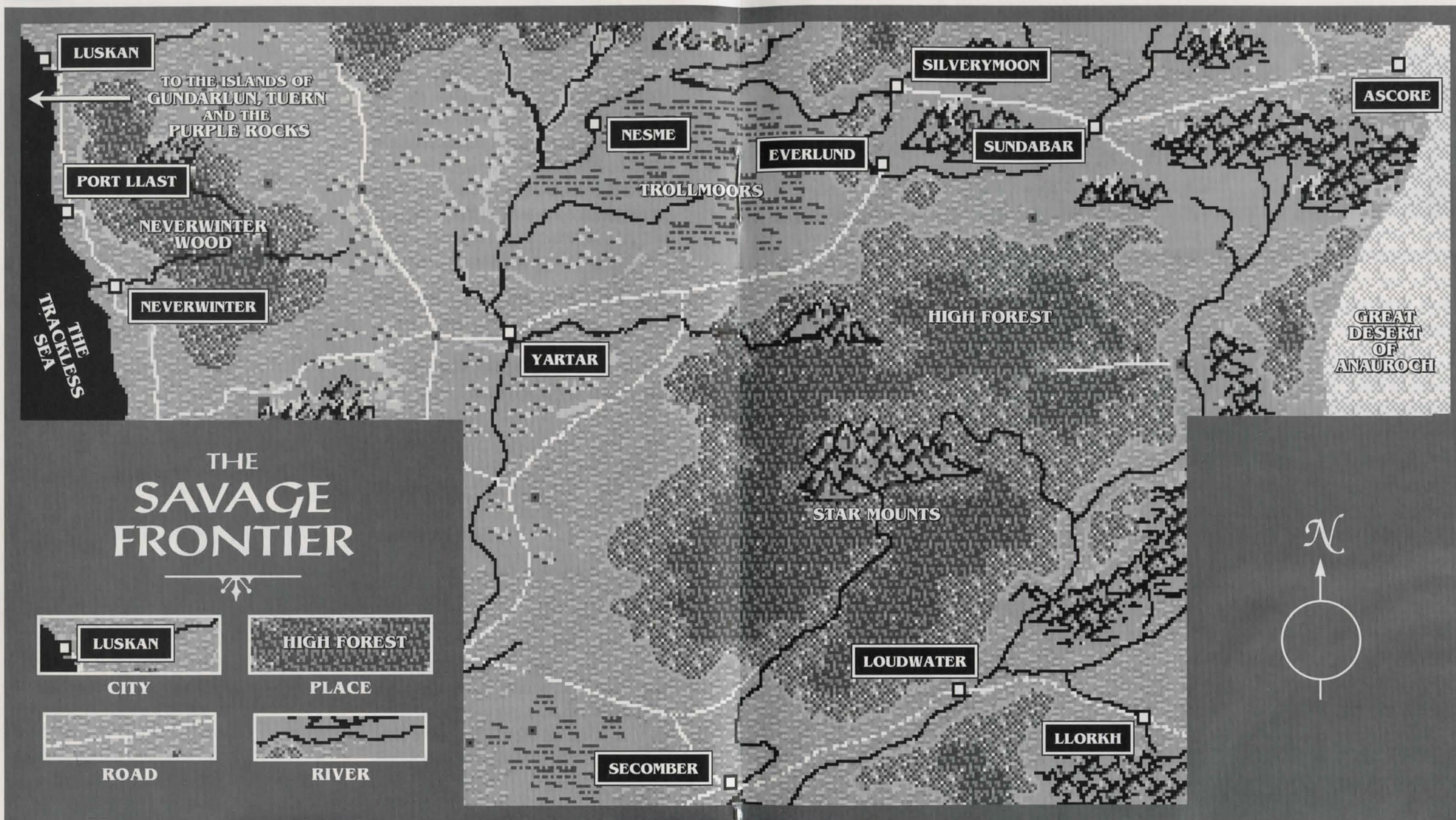

□ JOURNAL ENTRY 5

THE STOLEN REWARDS:

A curse upon their filthy heads! They've taken all we had, stolen everything save the clothes on our backs!

"More! More for everyone!" the waitress cried out at the tavern last night. We looked at each other, shame-faced at hav-

ing fallen for so old a trick. Someone slipped a little something in our food and we slept like contented babes while the bandits stole us blind!

All the gold earned on our last mission is gone. We endured those dangers, did our jobs and now are left with empty pockets! Our heads could have festooned the end of an orcsish pike. . . all for nothing!

They even took my fine magical sword with the gold braided handle, the one I used to slay the griffon at Longsaddle last winter. What I would give to have it one more time, if only to skewer the slime who committed this atrocity!

We still have the tiny purse of coins I kept beneath my pillow. There isn't much, but it will be enough to buy new weapons

and a few supplies. We need to find a new sponsor or a new mission quickly, to earn the money we need to live.

Whatever mission we next accept, we will have a second quest to complete as well: to catch these thieves and exact payment for last night!



“Our foes are many and varied, but we must always remember the face of our ultimate enemy...”

❑ JOURNAL ENTRY 6

THE GUARDS AT YARTAR:

“We’ve been ordered that no one be allowed to leave the city for the rest of the day. Travellers from the north report that many bands of trolls have been seen there, and some have been observed close to Yartar.”

“These alerts normally don’t last very long. If there’s anything you need to buy at any of the stores here in town, this is a good time to do it.”

❑ JOURNAL ENTRY 7

MAP OF THE ISLAND FORTRESS.

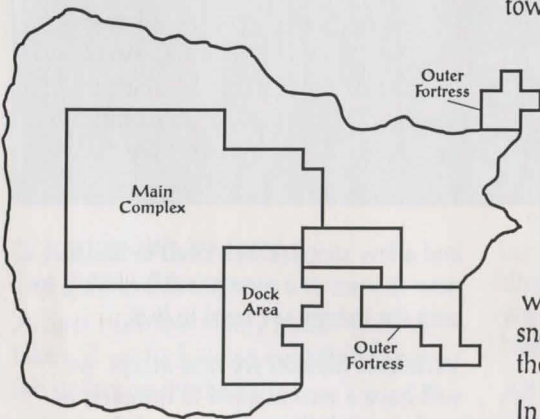

❑ JOURNAL ENTRY 8

THE STORY OF THE PRIESTESS OF WAUKEEN:

“I never knew that a secret door led into the back of the temple like this! I’m only glad that you are friends instead of enemies!”

“I’m sure the people who attacked you in the outer room were going to use the secret door to enter the temple and kill us all! As sure as the market hawkers gather in the morning, they were sent here by the barbarians, and Longresses herself. All she wants is control of the city, and she doesn’t care with whom she allies herself to get it!”

❑ JOURNAL ENTRY 9

THE WATERBARON’S WELCOME:

“Welcome, adventurers! I regret that all of your treasure and possessions have been stolen. If the City Guards should recover any of your items they will be returned to you.

“I also understand that you are in need of a commission, but I have nothing for you at this time. However, Yartar is a busy town filled with many people from all corners of the Realms. Perhaps in the streets you will find someone in need of help during these troubled times.”

❑ JOURNAL ENTRY 10

MIELIKKI’S FESTIVAL:

All around us there was activity, with the music of many lutes and the snap of a hundred banners flapping in the breeze.

In the heart of the glade a chorus of young girls sang a blessing of the trees, and the birds seemed to echo back a happy, chirping refrain.

People everywhere were walking hand-in-hand, talking softly and revelling in the beauty all around them. It was almost enough to make us forget the worries and dangers that had brought us here to Silvermoon.

❑ JOURNAL ENTRY 11

THE BARGEBUILDER’S STORY:

“I hope this panic about armies of orcs and trolls ends soon. We usually build two barges a month here. Now no one wants to send goods up river unless they have to, and we have no new orders.

“The river going east was always dangerous, but now going south is bad, too. Of course, the High Forest is still far more dangerous than any other place in this part of the Realms.

❑ JOURNAL ENTRY 12

THE COUNCIL MEMBER’S STORY:

“You may not care to listen to our sad tales, with your own horrid stories of orcish armies on the march, but here in Everlund strange things have been happening as well.

“Many undead have appeared in the old part of the city to the north, livestock have been disappearing from the pens near the river, and even stirges have been so bold as to attack people in the streets.

“What has our peaceful little town done to deserve such misery?”

❑ JOURNAL ENTRY 13

THE HARBORMASTER’S STORY:

“I tell ye, young ‘uns, the only reason that the Gallant Prince still be anchored here in Port Llast Harbor is we ain’t got no one who’s darned fool enough t’ board ‘er and tow ‘er out t’ sea.

“We’d all heard she wa’ missin’, then Simon Hempwright the fisherman says he spied ‘er adrift a mile off the coast, worm eat’n like she’d been a’ sea a hundred years. The young idiot towed ‘er in an’ tied ‘er up, an’ then he goes traipsing down below decks like she wa’ some pleasure barge out o’ Waterdeep.

“Course, we never seen ‘im no more after that, ‘cept some say you can hear ‘is screams a’ night way back in town.”

❑ JOURNAL ENTRY 14

LONGTRESSES ALARAUN’S STORY:

“Please, let me welcome you to Nesme. We have just completed a very unhappy task. I had to seize the city by force of arms to save it from the corrupt priests of Waukeen.

“By necessity, I enlisted the aid of some of the local. . . well, barbarians. And I do admit that now some of them are out of control. Take care as you travel through our streets, for my comrades are dangerous and love to fight.”

❑ JOURNAL ENTRY 15

THE SEARCH OF THE MAGE’S BEDROOM:

In the debris you find a scrap of paper with the inscription:

ENWNWN. Go straight between turns until you must turn again. Use the knock on hidden door to the right.

❑ JOURNAL ENTRY 16

THE MAÇE LIBRARIAN'S STORY:

"Oh my, oh my, it's good to see you! Yes, Amanitas and his assistant were indeed here, but look! Their room has been torn to pieces, and look at all this blood on the floor! Oh my, oh my!"

"I fear something terrible has befallen them. May Mystra guide you to his aid!"

❑ JOURNAL ENTRY 17

LORD NASHER'S STORY:

"I'm afraid you've come to Neverwinter in a time of great troubles. Many people were moving to the outskirts of the city to escape the troubles. The older, inner areas were becoming havens for criminals and all forms of monsters.

"We converted several blocks of the old city to indoor gardens to help bring people back to Neverwinter. But now monsters have invaded the indoor gardens. Instead of bringing people in and helping the city, the gardens are scaring them away!"

❑ JOURNAL ENTRY 18

THE NESME HARBORMASTER'S STORY:

"It's not my fault! The story's the same in many towns on the river, not just here in Nesme! They can't blame me for this, no, no, they can't!"

"The warehouses on the eastern side of the river have been beset by a plague of giant frogs, and lizard men have been feasting on the herds in the stock pens to the west shore. Now the shipping companies won't stop here because of the danger!"

❑ JOURNAL ENTRY 19

A PORTION OF THE HOSTTOWER DUNGEON.

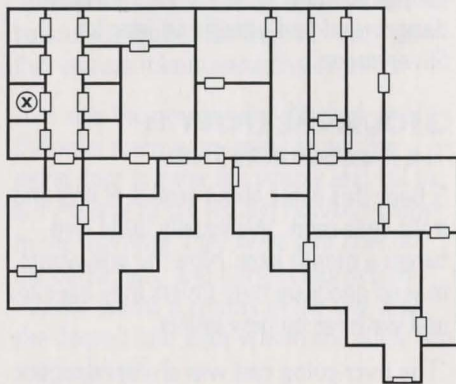

❑ JOURNAL ENTRY 20

A MAP FOUND IN SILVERMOON.

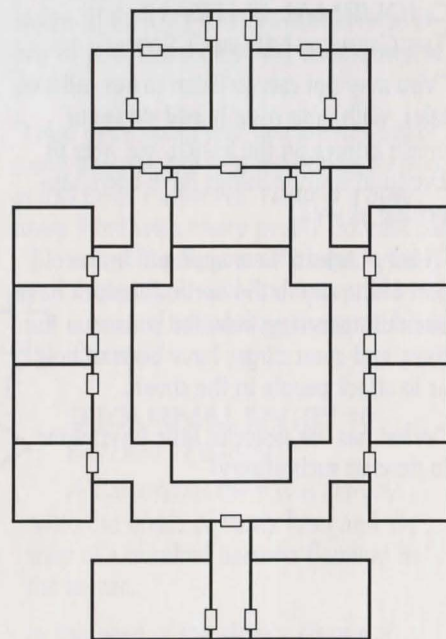

❑ JOURNAL ENTRY 21

KREVISH'S STORY:

"You know, I'd sure love to do something for you guys! If you're looking for work I have some friends here in Yartar who hire adventurers all the time and maybe they have something you could do and that way you could get back on your feet again and I would've helped you and I would've repaid you for saving my life and we'd be friends and wouldn't that be great!"

❑ JOURNAL ENTRY 22

VAAFGAMON'S TAUNTS:

"You pathetic little simpletons! Did you think that a puny group of snivelling would-be heroes like yourselves could change one iota of my plan!!

"Vaalgamon does not deal with your kind! Hah! I can snuff out your lives with the heel of my boot as I would the tiniest of carion-crawling insects! I will leave the trivial task of killing you to my Kraken hosts."

He turned and swept out of the room, as the heavy door slammed shut behind him.

❑ JOURNAL ENTRY 23

THE SAILOR TURNED TO STONE:

Beside the statue we found a crumpled note:

"They wanted the sea lanes clear between Luskan and the Purple Rocks, and any ship they found there they took over or destroyed. We were only one of the sad vessels in their path.

"One by one the undead they commanded have killed our crew, transforming them into lonely wanderers like themselves. Soon it will be my turn. I only hope that the tall one turns me to stone, as he did the Captain, so I may be spared such eternal torture.

"Some are Krakens, but the magic-user is from a great tower somewhere to the north. He kept taunting the Krakens, saying they needed to go to all this trouble because they were not clever. He said that the wizards of the tower had great power, but that they were clever too. He said their treasure was hidden in the opposite direction from where anyone would ever look."



“ The High Forest has always been dangerous, but now, even the cities of the north are beset by monsters. ”

❑ JOURNAL ENTRY 24

INTO THE HIDDEN COMPLEX:

We followed Krevish around several corners and down an alley, where he pressed a hidden panel in a wall. A door swung open, and after some hesitation we let him lead us into a dark corridor. Our weapons and armor clanked loudly as we walked cautiously down the passageway, finally arriving before a heavy wooden door.

Krevish knocked on the wood in a complex pattern of beats with both knuckles and palm, and in a moment it was opened by an angry-looking man in well-crafted armor.

□ JOURNAL ENTRY 25

THE MEETING BENEATH YARTAR:

The man looked us over for a moment, not at all sure whether he liked the idea that Krevish had brought our party to his secret lair.

"It's all right, Captain!" Krevish piped up enthusiastically. "They saved my life! They didn't have to do it, they could have just kept on walking, but they stopped and risked their lives to save mine and that was really nice of them and that's why you really ought to give them a chance to carry out a mission for us because they've really earned a chance I think, don't you?"

The Captain rolled his eyes. "All right, Krevish, all right," he sighed. "If you'll just be quiet I'll give them a chance."

"As you know," he told us, "the Temples of Bane are dedicated to the advancement of Evil in the Realms. One cleric of Bane in the town of Nesme, up the river to the north of here, has been causing great disruptions in that city.

"We believe that to save Nesme from civil war he must be stopped. If you can find the Banite Cleric, and carry out this mission, you will have proven yourselves to be as valuable as Krevish here says you are. Well. . . almost as valuable, anyway."

□ JOURNAL ENTRY 26

THE COLLEGE DEAN'S STORY:

"It's really been quite terrible, quite awful here. The areas near the docks on the north bank of the river are full of lizard men and other monsters. Here! In Silvermoon! It's unheard of!"

"It's as if someone was trying to keep the good law-abiding folk away from the river. Perhaps the orcs plan a great offensive and are trying to deprive us of supplies.

"What will become of us? Silvermoon was such a peaceful town. I just don't know. . . ."

□ JOURNAL ENTRY 27

THE CAPTAIN OF THE RIDERS OF NESME'S STORY:

"Yes, we too have heard the stories of the trolls gathering in a great army to the east in the Trollmoors, and now small groups of them have been seen in the ruins to the east of the city.

"We should be going out to drive them back! We should be scouting the moors to see what's going on! But are we! No! We're confined to barracks because Longtresses Alaraun has taken over. If we go near the city now, the crazy barbarians will start a full-scale war!"

□ JOURNAL ENTRY 28

EREK'S STORY:

"Don't just stand there! Amelior Amanitas, the brilliant magic-user for whom I work, is in great danger! They said they were taking him up the river to Everlund, and from there overland to Lorkh and on to Zhentil Keep! They were furious that he'd discovered their plan, and there's no telling what they'll do to him once he's there!

"If we don't find him before they leave Everlund we'll never have a chance — there are so many routes they could take towards Lorkh. . . we have to find him quickly!"

□ JOURNAL ENTRY 29

THE CHALLENGE OF AMANITAS:

We quickly summarized for Amanitas what we had learned thus far. We also told how some Banites believed that only he could stop the forces of Zhentil Keep from conquering the lands of the Savage Frontier.

"What was revealed to you by the Banites is correct," he said when we'd finished. "I learned much of the tale from an escaped slave who had been a servant to the Zhentarim general Vaalgamon, and my investigations since have only served to confirm how great the danger truly is.

"Although most of their story has been lost in time, I know now that four statuettes were created in ancient Ascore. They were powerful magical items used in the defense of the city, although precisely how they worked is still a mystery. One was crafted to focus on each direction of the compass, protecting Ascore from enemies to the North, East, West and South.

"When the city fell into ruins the statuettes passed from owner to owner throughout the Savage Frontier for many centuries. They travelled in directions very different from their names. For example, the Statuette of the East has for many years been hidden somewhere in the west.

"Now the Zhentarim have dispatched Vaalgamon to collect the statuettes. They believe that by returning the statuettes to Ascore they can open a safe path through the Great Desert. Through that path they intend to send armies to conquer the entire Savage Frontier.

"We must find and seize the statuettes before Vaalgamon can collect them, or a pall of darkness will fall across the north.

"My magical investigations cannot tell me exactly where they are located, but I have a sense of the place where each statuette now lies. To find them you cannot follow a map of the road beneath your feet — I can lead you to your goals only by revealing the pathways you must trace within your own souls.



“We rushed forward as the documents burst into flame. All we could save was a part of one small paper.”

"First, you must lift your eyes with hope, even if the vision which fills them is one of evil. The Statuette of the East is located in a great tower, and when you look up at its many spires you shall know that you have found it.

"Next, you must seek small truths within the large, unfathomable world, for these are the only truths you will ever truly know. The Statuette of the West lies in a small chest carved from the pearl of a great oyster, in a small room carved from the rock of a great mountain, which is itself made small by the greatness of the sea.

"You must then travel to the place to which people do not wish to go, because we never truly covet that which we can easily attain. The Statuette of the North lies nowhere close by, but on the long way that many travellers nonetheless must pass.

"Then you must soar where even the birds cannot fly, and have faith that even without wings you can reach great heights. The Statuette of the South lies both high above and far below the surface of the land.



“P-P-Pirates? No pirates here in Luskan, no sir. Never seen one here. Not a one. No, no pirates here!”

"If you gain the four statuettes, take them to Ascore. I have created one more special item which, when combined with the four ancient images, will turn the Zhentarim's planned triumph into total and irreversible defeat. But this can only be accomplished in the ancient plaza at Ascore."

He reached into his robes and drew out a small, square card that looked like it was made of a thin layer of metal. Runes were embossed upon it.

"This isn't it!" he exclaimed, annoyed. "But I suppose you should take it anyway. It's one of my latest inventions. I call it the Card of Counting. If you carry it the vaults in Yartar, Neverwinter and Silverymoon will all save and exchange your valuables as if they were really just one place. Could be quite handy, yes, quite handy. Don't leave here without it.

"Well, that's it! Good luck to you, and may you find the path easy to follow. You can come visit me any time at my house in Secomber, and if I've learned more about

any of the statuettes I'll be happy to share the information with you. Good bye!"

"The magic item?" we asked. "There was an important magic item you were going to give us!"

"Oh yes, yes, yes. Mustn't forget it. Very important." He searched through his robes once more. . . .

□ JOURNAL ENTRY 30

BRINSHAAR'S STORY:

"My name is Brinshaar, and I am a magic-user from Neverwinter. They kidnapped me there and were torturing me to learn of Lord Nasher's magical defenses. Thanks to you they learned nothing, and Neverwinter remains safe!

"As it turns out, I can repay you for your kindness without delay. I have seen the statuette you tell me that you seek. It is not secreted in the Hosttower, but somewhere in the dungeons where we now stand."

□ JOURNAL ENTRY 31

THE BANITE CLERIC'S LETTER FRAGMENT:

". . . that you found the explanation for the gatherings of trolls and orcish armies in the north. I had suspected it was the work of the Zhentarim, and if we had not discovered it in time they might have conquered this entire region.

"The fools believe that it is their cunning and their might that brings them such awesome power. Have they forgotten so quickly about the Temples of Bane, and the power that even our own leaders cannot abdicate? That we, the clerics who carry out Bane's will, are the ones who have made the name of the Zhentarim feared throughout the Realms!

"I agree with your letter, and although we have never met I feel closely bound to you. By destroying this plan before it starts

we shall ensure that never again will the Banite clerics be taken for granted in Zhentil Keep!

"I will meet you during the Festival of Mielikki in the hidden temple behind your shop in Silverymoon. We shall find the magic-user from the south who can turn the power of the Zhentarim against itself. Then we shall see how brilliant the Zhentarim prove to be!

"We must not think that because we know about their plans to cross the desert it will be simple to stop them. I am confident we will be successful within days only because. . ."

The remainder of the letter was destroyed, and the ashes crumble to nothingness in my hands.

□ JOURNAL ENTRY 32

THE WATERBARON'S WARNING:

"I must ask you to leave this place immediately! Great forces here seek your destruction. I will not help them but neither can I stand in their way. Go now!"

□ JOURNAL ENTRY 33

BROADHAND'S STORY:

Broadhand led us into a small, hidden room decorated with images and statues of Bane. He obviously believed us to be fellow Banites from the temple at Nesme.

"I was worried when I sent my letter and no messenger came bearing a reply. I'm glad to see you've arrived during the Festival as I suggested.

"Once the Zhentarim would have been content with having found a way to open this safe caravan route through the Great Desert. They would have let time pass, allowing towns and villages to become dependent on a supply route that only the

Zhentarim controlled. Then, quietly but inexorably, the hidden reins of power would be pulled into their grasp.

"Now their greed to seize the northern Realms is unbounded and impatient. Sending armies across the Great Desert! Who would ever have believed it!! They have forgotten that a single dagger at midnight may sow greater terror than 10,000 swords at dawn!

"Even now they are completing their complex on the eastern edge of the desert, and are reclaiming the dead city of Ascore on the western edge as well. They have forged alliances with the Krakens and with other forces in the North. I also hear tales that something big is going on in Llokh. Magic items of great power are being collected for the task, and I have been assured that they do indeed have the power to allow the safe crossing of the desert!

"We must strike now! Controlling the Realms from the Moonsea to the Sea of Swords will greatly strengthen the Zhentarim, and the historic balance between the Zhentarim and the Banites will be lost!

"Visiting here in Silverymoon at the Vault of the Sages is the wizard I wrote you about, Amelior Amanitas from Secomber. He learned much of this plot from a slave who had escaped from a Zhentarim caravan, and is convinced he can stop it with his magical powers.

"He sent a message to a fellow wizard here in Silverymoon, but one of my acolytes waylaid the courier and we learned of the plan. Since Amanitas has now come here himself, he must have received word of the messenger's death and is willing to take great risks to defeat the Zhentarim.

"You must find Amanitas quickly. Help him in this task, but do not tell him you are Banites or he will never listen to you. For all his brilliance he refuses to accept the beauty of pure Evil, and will never know the joy we find in Bane.



“The huge ship beat its way through the rising waves. The great letter on its main sail made it quite clear who we were dealing with.”

"Hurry now! As we speak our enemies make progress on their path!"

He slipped out of the room, motioning for us to wait a short time before leaving to complete our "mission."

❑ JOURNAL ENTRY 34

THE ESCAPE OF THE PRISONERS:

Three men rushed from the tiny cell, their clothes in tatters, eyes drawn from lack of food and sleep.

One stopped to look down at the dead Banite, and a broad smile spread across his hollow face. "Looks like you've done the job we were sent to do!" he said, laughing unnaturally. "Now we can go home and take the credit! We of the Zhentarim salute you!"

His companions blanched as he said the forbidden word — only others dare to use that name, never the Zhentarim themselves. They cursed in hushed voices, pulled him from the room, and were instantly out of sight.

We looked at each other helplessly. Because we knew the Banite to be evil, we had slain him — the one man who could stop the Zhentarim's plan for the conquest of the Savage Frontier. There was no choice. We had been searching for a mission. Now, by accident, we had found one. We would have to save the northern Realms ourselves.

❑ JOURNAL ENTRY 35

THE KRAKEN STRONGHOLD:

The castle that rose above us was so great in size that it dominated the entire island, as if it were a statue and the whole of Trisk were only its base.

The front of the building was carved in the image of a massive squid that rose a hundred feet above the island, its huge eyes glowing from some frightful, hidden light. Behind it the building gradually transformed into a heavily fortified castle, with high parapets that seemed to go on and on until they merged into the cliff-sides of the coast.

❑ JOURNAL ENTRY 36

THE ODD MESSAGE OF THE KRAKEN:

css al a i gad. csl te o cre suhet te t i tk wl
gad te trae i. dc te t dw do suh te truh vut
is fo tkn b wl sau te.

❑ JOURNAL ENTRY 37

THE ARENA BENEATH LLORKH:

The arena in which we stood was broad and spacious, surrounded by seats for several thousand spectators.

Most of those seats were already filled. Several hundred black-robed men sat in one section, beside an equal number of other humans and a few strange-looking beings in the shadows — they may have been drow elves. Separated from the

humans by a respectfully wide zone of empty seats, the remainder of the arena was filled by orcs, with a scattering of goblins and even bugbears.

The great bowl was filled with the din of a thousand conversations, but every voice was silenced at once when a guard called out, "All rise for Lord Vaalgamon!"

The familiar figure of the Zhentarim general strode onto a dais on the western side of the arena and motioned for his followers to be seated.

"Well, my friends!" he told us, a hideous smile distorting his already-twisted features. "I see we have the pleasure of meeting again!"

"I must say that I admire the courage and cunning that have brought you this far. You have defeated forces that should have defeated you. Their deaths at your hands are appropriate punishment for their failure.

"As a reward for your achievements, I will give you all a chance. Defeat three sets of opponents in my arena and I shall let you live.

"Let the combat begin!"

Across the arena a steel grating opened, and we turned to face our first opponent. . .

❑ JOURNAL ENTRY 38

KING THRELKED IRONFIST'S STORY:

"Ever since the reports of the meteorite strike on the north end of the island, many adventurers have come here seeking ore for magical swords. However, no one on this island can craft such fine weapons.

"I warn all adventurers, but few listen. There are many canyons that cut across the island, and some have networks of

great volcanic caves filled with fearsome monsters. Only parties of veteran adventurers should dare to enter them."

❑ JOURNAL ENTRY 39

A MAP FOUND IN THE OTYUGH'S LAIR.

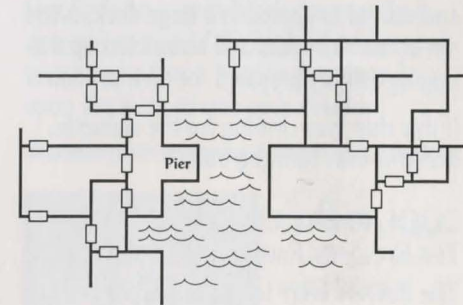

❑ JOURNAL ENTRY 40

THE UThERAAL VILLAGER'S STORY:

"The headquarters of the Kraken Society is on Trisk, the other island just across the strait. They also have fortresses here on Utheraal, on the western coast, where they force us to pay tribute.

"They take almost everything we have, but if we don't pay they will take us away as slaves. I don't know if you can defeat them, but whatever you do can only make our lives better."

❑ JOURNAL ENTRY 41

THE ZHENTARIM SHIP ARRIVES:

Rounding a rocky point far below us was a ship with a single huge, red sail. A large black "M" filled its billowing expanse, which we could only speculate was the symbol of Lord Manshoun, the leader of Zhentil Keep.

A single man stood at the railing near the bow, his black cape flowing behind him in the stiff sea breeze. Could it be Vaalgamon himself?

The ship swung to the northwest, its sail dropping as it entered the lee of the island and started to approach a large dock. Men ran across the decks and scrambled up the rigging as they prepared for their arrival.

If this ship was coming for the statuette, our time was running out!

❑ JOURNAL ENTRY 42

THE STORY OF PHINTARN REDBLADE:

The flowers were left in beautifully woven baskets beside the street, and had delicate hand-embroidered ribbons on them. One said simply "In memory of Phintarn Redblade, Last Ruler of Llorkh." Another read:

"Tonight thy killers sit within thy Keep, But soon they'll lie beneath it. . . six feet deep."

A guard wandered by and saw us looking at the flowers. Drawing his sword, he knocked them from my hand and crushed them with his boot. "If you're a dwarf-lover," he warned us, "Llorkh is no place for you!"

❑ JOURNAL ENTRY 43

MUTHTUR'S STORY:

As if he'd read our thoughts, the creature said, "Yes, I'm a half-orc and to you I'm ugly as an otyugh. I'm also the hideous, inhuman thing that saved your lives."

We all looked at each other, embarrassed, and several of us murmured our thanks.

"I lived with a small colony of other outcasts in the High Forest, until raiding par-

ties from Llorkh captured me and brought me here. They called me a 'novelty fighter' and said it'd be fun to watch something different in the arena for a change.

"I'm no novelty, I'm a person. And I killed the man who said it. My name is Muthtur and all I want to do is go home.

"When they brought me here I saw them use a secret door in the north alcove of the arena. I don't know where it leads, but it may help us all get out of here."

❑ JOURNAL ENTRY 44

THE POTTER'S STORY:

"I overheard our captors saying that fire giants have been preying on any adventurers who were lucky enough to find meteorites. The giants sell the stolen ore to pirates in exchange for gems, grain, or even some of us as slaves."

She shivered visibly and thanked us once again for saving them.

❑ JOURNAL ENTRY 45

THE DYING ZHENTARIM'S DEFIANCE:

"You may have gotten this far, but even if you could get all the statuettes you'd never make it to Ascore. . . Vaalgamon is far too clever for you, and our power is too great. . . .

"Enjoy your triumph for tonight, for it will rot into disaster by tomorrow!"

❑ JOURNAL ENTRY 46

THE STORY OF THE HIDDEN DWARVES:

"We have been prisoners in our own city ever since Lord Redblade was killed. They say it was an accident, but we all know it was the Zhentarim that killed him, and that it is they who control Llorkh. Geildarr is only a puppet, an outsider brought here by them to control the town.

"Just a few days ago a Zhentarim column came through Llorkh, and they murdered any dwarf they could find. That's why we're now in hiding — this is the lair of a medusa, but even with her hell hound guards we are safer here than on the city's streets."

❑ JOURNAL ENTRY 47

KESTUTIS' STORY:

"My name is Kestutis, and I was once a knight who served the Kings of Tuern and Gundarlun. In those days the two islands were friends, not the tense rivals they have come to be.

"Here on Tuern I dared to enter the hottest volcanic vents in search of evil fire giants who terrorized Uttersea, and the old King gave me this ancient fortress as a reward for my service.

"I am impressed by your valor and your skill in taking on the mission you have described. Just as I risked my life in service to the people of the North, so you are risking yours. Take this, the Armor of the Glacier that I wore during my service — it will give you protection against fire and against the monsters which it spawns."

❑ JOURNAL ENTRY 48

THE SIGNS AT SECOMBER:

"The road and river to the east have become very dangerous. Go only if you need to, and try to travel with a strong group of experienced adventurers."

— Selam

❑ JOURNAL ENTRY 49

THE KRAKEN'S CODED MESSAGE:

o t l t u r . a t e h f o n r o t w s h o t a e i l u r s h
h e t n d f . o k h o o n o r o t h h o g a l t r m a e e
i l t t e h .

❑ JOURNAL ENTRY 50

THE AARAKOCRA'S STORY:

"High atop the Star Mounts the birds cannot go. Our homes are there, and only we and the dragons can brave the fierce winds that blow through the mountain-tops. We have seen black dragons fly to an aerie on one of the highest peaks, and saw it to be that a human female rode upon the back of one such dragon.

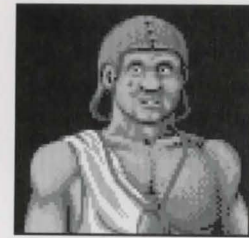

“ The Star Mounts... I've never heard of anyone who went there and came back to tell the tale. ”

"We have heard that the chambers within the mountain be crafted as a maze. It has been told that the corridors be in the form of the first initial of their owner in three different runic alphabets, each superimposed upon the other and on their own inverses, so that the letters are entwined in many layers."

❑ JOURNAL ENTRY 51

THE GUILTY CITIZEN'S STORY:

"I didn't want to help them, really I didn't. I haven't taken a share of pirate booty in years. They said if I didn't report on Jagaerda's movements they'd turn me over to the King!"

"I don't know where they have her! I took my reports to a house hidden away among the cliffs on the southern coast. Please spare me! I've told you everything I know!"

❑ JOURNAL ENTRY 52

THE KRAKEN'S CODED MESSAGE:

etuw lek msu rgt u rwtt k. ite edea leto e
uw to eot se. gria a s.



“Never had we seen such a sinister construction. Our hearts quaked, but we advanced nonetheless...”

❑ JOURNAL ENTRY 53

AN OUNCE OF JUSTICE:

Several weapons were stacked in one corner of the room, and suddenly I cried out in delight.

My magical long sword, the gold braid on its handle tarnished but undamaged, lay amidst the pile of crudely crafted weapons! I ran over, pulled it from its sheath and examined the blade — still sharp and true as any arrow fired from Helm's bow!

Whatever evils might stalk the Realms, I knew that for this one moment justice had been done. The gold they'd stolen from us at the Inn was gone forever, but with this sword our honor was restored!

❑ JOURNAL ENTRY 54

CEPTIENNE'S WELCOME:

"Welcome to my home," the image said, smiling. "My name is Ceptienne, and I know that you are here to steal the Statuette of the South from me." She waited for the effect of this proclamation to take hold.

"You have proven yourselves worthy adversaries to have gotten this far, and I enjoy the challenge of a clever enemy. I shall kill you. . . yes, that much is certain. But I shall give you a chance to find the object that you seek."

A great crystal globe beside her flickered to life, and the statuette appeared within it. "My fortress here has many portals. Twelve now stand between you and your objective. I shall follow your movements with interest."

She smiled once more and the image faded from view.

❑ JOURNAL ENTRY 55

KING REDAXE TELLS OF THE PURPLE ROCKS:

"The Purple Rocks may be the isles you seek," said the King. "They have become a sad place. Their people were like other island folk, hardworking, many of them seafarers. A few generations ago something strange occurred, and many gathered in a secret cult which has become very powerful, called the Kraken Society. They worship the symbol of the Kraken, a huge squid that can easily destroy great ships.

"There are two islands in the Purple Rocks, Utheraal and Trisk. The people of Utheraal are impoverished, but continue to live as before. The people of Trisk, however, have been completely consumed by the Krakens and are controlled by them.

"I know you have been to Tuern already, but it is there that you have the best chance of finding someone who will take you to the Purple Rocks. May Selune guide you on your journey."

❑ JOURNAL ENTRY 56

THE MAN OF MIRRORS' STORY:

"I search and research. . . I find the hidden. . . I solve the unsolvable. I find reason within chaos and harmony from the stars.

"Vaalgamon has entrusted to me the riddle of the mirror-maps and they shall not defeat me! Already I have confirmed much of what they tell, and soon I shall give the general everything he seeks and more!"

❑ JOURNAL ENTRY 57

THE MAGIC MOUTH'S STORY:

"You have done well, adventurers," the stone face said. Its voice was deep and its features expressionless, but the tone of its words was warm, almost friendly.

"It is time for you to reap your reward. Look within the waters of my fountain and discern what riches can await you!"

Everyone looked at the spraying water as an image began to form there. The vision showed a pool filled not with water, but with gold. Each member of the party was swimming in it, leaping about and laughing and tossing coins in the air.

The image faded. "That was a dream, my friends, but it is a dream that you can make real. Drop the statuettes in my warm waters and this ocean of gold shall be yours!"

❑ JOURNAL ENTRY 58

A MIRROR MAP FROM THE HIGH WALL.

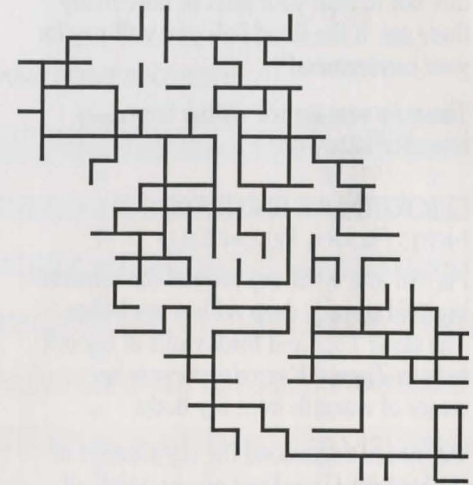

❑ JOURNAL ENTRY 59

THE OLD THIEF'S STORY:

"I was once an adventurer like you, in service to the Lords' Alliance, and a fine pickpocket when it came to relieving our enemies of their documents. . . and perhaps an occasional jewel to compensate me for my trouble!

"He was a contemptuous buffoon, Vaalgamon was, pushed me down in the street as he passed by, for no good reason. I may be an old man, but I still have the touch! I saw to it that Vaalgamon didn't leave Sundabar with everything he'd brought!" He held out an aged but steady hand, presenting an envelope with a broken wax seal.

We opened the envelope and removed what seemed to be a hastily scribbled note:

"Fool! You allow one tiny band of mongrels to threaten everything our legions now pursue!

Get to the pyramids at Ascore without delay! Let no one pass through the stronghold! Guard every pathway — I care not to hear your tales of how many there are. If the Road fails you will pay for your carelessness!”

The note was signed with a large, scrawled letter “M”.

❑ JOURNAL ENTRY 60

NOTES FROM A PRISON CELL:

As I sit and write my journal the unrelenting cold spreads deep within my bones. The stone floor and thick walls of my cell here in Zhentil Keep drain every last ounce of warmth from my body.

We never understood the significance of the statuettes, nor their power. With all four in his possession, Vaalgamon achieved his goals, and all the northern Realms fell under the Zhentarim shadow.

Our riches have availed us nothing. We were hunted down, captured, and brought to this prison, where they keep us alive only out of a desire for revenge. If only we had the chance to live the past over once again. . . .

❑ JOURNAL ENTRY 61

A MIRROR MAP FROM THE HIGH WALL.

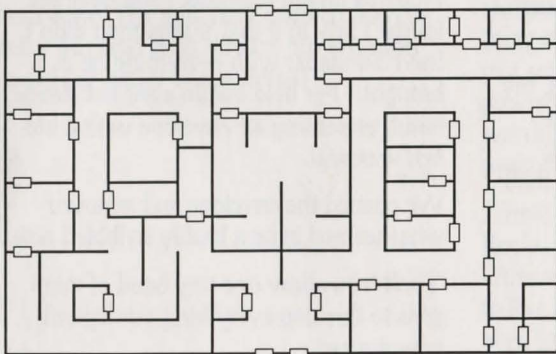

← North

❑ JOURNAL ENTRY 62

A LONELY LAMENT:

I hear the sound of many footsteps approaching. I'm sure that they will find us soon.

If we had known of Ceptienne's true role as an opponent of the Zhentarim, the real statuettes would have been ours instead of the false ones we now hold.

We must assume that Vaalgamon's boastful speech was correct, and that the High Forest holds the spot where the magical path across the desert ends.

But to know this now is useless. We have fallen into his trap and we are his to play with, as a cat plays with the mouse it is about to devour.

Perhaps others will follow us on this path and find that victory awaits them instead of death.

TABLES

MAXIMUM LEVEL LIMITS BY RACE, CLASS AND PRIME REQUISITE

CLASS	ABILITY	DWARF	ELF	GNOME	HALF-ELF	HALFLING	HUMAN
Cleric	Any	no	no	no	5	no	6*
Fighter	STR 16-	7	5	5	6	4	8*
	STR 17	8*	6	5	7	5	8*
	STR 18+	8*	7	6	8*	no	8*
Paladin	Any	no	no	no	no	no	8*
Ranger	STR 16-	no	no	no	6	no	7*
	STR 17	no	no	no	7*	no	7*
	STR 18+	no	no	no	7*	no	7*
Magic-User	INT 16-	no	6*	no	6*	no	6*
	INT 17	no	6*	no	6*	no	6*
	INT 18	no	6*	no	6*	no	6*
Thief	Any	8*	8*	8*	8*	8*	8*

no: Characters of this race cannot be of this class.

*: Highest Level Available in Gateway to the Savage Frontier.

RANGE OF ABILITY SCORES BY RACE

ABILITY	DWARF	ELF	GNOME	HALF-ELF	HALFLING	HUMAN
Strength	M/F	M/F	M/F	M/F	M/F	M/F
Min.	8/8	3/3	6/6	3/3	6/6	3/3
Max.	18/17	18/16	18/15	18/17	17/14	18/18
Intelligence						
Min.	3/3	8/8	7/7	4/4	6/6	3/3
Max.	18/18	18/18	18/18	18/18	18/18	18/18
Wisdom						
Min.	3/3	3/3	3/3	3/3	3/3	3/3
Max.	18/18	18/18	18/18	18/18	17/17	18/18
Dexterity						
Min.	3/3	7/7	3/3	6/6	8/8	3/3
Max.	17/17	19/19	18/18	18/18	18/18	18/18
Constitution						
Min.	12/12	6/6	8/8	6/6	10/10	3/3
Max.	19/19	18/18	18/18	18/18	19/19	18/18
Charisma						
Min.	3/3	8/8	3/3	3/3	3/3	3/3
Max.	16/16	18/18	18/18	18/18	18/18	18/18

M/F= Male/Female.

ABILITY SCORE MODIFIERS BY RACE

RACE	MODIFIERS
Dwarf	Constitution +1, Charisma -1
Elf	Dexterity +1, Constitution -1
Gnome	none
Half-elf	none
Halfling	Dexterity+1, Strength-1
Human	none

STRENGTH TABLE

ABILITY SCORE	THAC0 BONUS	DAMAGE ADJUSTMENT	WEIGHT ALLOWANCE (IN GOLD PIECES)
3	-3	-1	-350
4-5	-2	-1	-250
6-7	-1	none	-150
8-9	normal	none	normal
10-11	normal	none	normal
12-13	normal	none	+100
14-15	normal	none	+200
16	normal	+1	+350
17	+1	+1	+500
18	+1	+2	+750
18/01-50*	+1	+3	+1,000
18/51-75*	+2	+3	+1,250
18/76-90*	+2	+4	+1,500
18/91-99*	+2	+5	+2,000
18/00*	+3	+6	+3,000

*These bonuses available to fighter classes only (Fighter, Paladin, Ranger).

MULTIPLE ATTACKS FOR FIGHTER-TYPE CHARACTERS

MONEY CONVERSIONS

CLASS LEVEL	ATTACKS PER ROUND	COIN TYPE	GOLD EQUIVALENT
Fighter 1-6	1/1	Copper	200 cp = 1 gp
Paladin 1-6	1/1	Silver	20 sp = 1 gp
Ranger 1-7	1/1	Electrum	2 ep = 1 gp
Fighter 7+	3/2	Gold	1 gp = 1 gp
Paladin 7+	3/2	Platinum	1/5 pp = 1 gp

DEXTERITY TABLE

ABILITY SCORE	REACTION/MISSILE BONUS	AC BONUS
3	-3	+4
4	-2	+3
5	-1	+2
6	0	+1
7	0	0
8	0	0
9	0	0
10	0	0
11	0	0
12	0	0
13	0	0
14	0	0
15	0	-1
16	+1	-2
17	+2	-3
18	+3	-4

CONSTITUTION TABLE

ABILITY SCORE	HIT POINT ADJUSTMENT	RESURRECTION SURVIVAL
3	-2	40%
4	-1	45%
5	-1	50%
6	-1	55%
7	0	60%
8	0	65%
9	0	70%
10	0	75%
11	0	80%
12	0	85%
13	0	90%
14	0	92%
15	+1	94%
16	+2	96%
17	+2 (+3)*	98%
18	+2 (+4)*	100%

*These bonuses available to fighter classes only (Fighter, Paladin, Ranger).

ARMOR AND WEAPONS PERMITTED BY CHARACTER CLASS

CLASS	MAX ARMOR	SHIELD	WEAPONS
Cleric	any	any	club, flail, hammer, mace, staff, staff sling
Fighter	any	any	any
Paladin	any	any	any
Ranger	any	any	any
Magic-User	none	none	dagger, dart, staff
Thief	leather	none	club, dagger, dart, sling, one-handed swords, short bow

ARMOR TABLE

ARMOR TYPE	WEIGHT IN GP.	AC	MAXIMUM MOVEMENT*
None	0	10	-
Shield#	50	9	-
Leather	150	8	12 squares
Padded	100	8	9 squares
Studded	200	7	9 squares
Ring Mail	250	7	9 squares
Scale Mail	400	6	6 squares
Chain Mail	300	5	9 squares
Banded	350	4	9 squares
Splint Mail	400	4	6 squares
Plate	450	3	6 squares

* A character carrying many objects, including a large number of coins, can be limited in movement to a maximum of 3 squares per turn. # A Shield subtracts 1 AC from any armor it's used with.

WEAPONS TABLE

NAME	DAMAGE VS. MAN SIZED	DAMAGE VS. LARGER THAN MAN SIZED	NUMBER OF HANDS	CLASS
Axe, Hand	1-6	1-4	1	f
Bastard Sword	2-8	2-16	2	f
Battleaxe	1-8	1-8	1	f
Broad Sword	2-8	2-7	1	f,th
Club	1-6	1-3	1	f,cl,th
Composite Long Bow*	1-6	1-6	2	f
Composite Short Bow*	1-6	1-6	2	f
Dagger	1-4	1-3	1	f,mu,th
Dart	1-3	1-2	1	f,mu,th
Flail	2-7	2-8	1	f,cl
Halberd	1-10	2-12	2	f
Hammer	2-5	1-4	1	f,cl
Javelin	1-6	1-6	1	f
Light Crossbow#	1-4	1-4	2	f
Long Bow*	1-6	1-6	2	f
Long Sword	1-8	1-12	1	f,th
Mace	2-7	1-6	1	f,cl
Morning Star	2-8	2-7	1	f
Scimitar	1-8	1-8	1	f,th
Short Bow*	1-6	1-6	2	f,th
Short Sword	1-6	1-8	1	f,th
Sling	2-5	2-7	1	f,th
Staff	1-6	1-6	2	f,cl,mu
Staff Sling	2-5	2-7	2	f,cl
Spear	1-6	1-8	1	f
Trident	2-7	3-12	1	f
Two-Handed Sword	1-10	3-18	2	f

* Must have ready arrows to fire. Two Attacks per round. # Must have ready quarrels to fire. One Attack per round. f=fighter, cl=cleric, th=thief, mu=magic-user.

Spell Parameters List

This is a listing of spells available to player characters as they gain in level. Following are abbreviations used in the list:

Cmbt = Combat only spell	All = All characters in combat
Camp = Camp only spell	r = combat rounds
Both = Camp or Combat spell	t = turns
T = Touch Range	/lvl = per level of caster
dia = diameter	targets = aim at each target.
rad = radius	

FIRST LEVEL CLERICAL SPELLS

SPELL NAME	WHEN	RNG	AREA	DURATION
Bless	Both	6	5 dia	6r
Curse	Cmbt	6	5 dia	6r
Cure Light Wounds	Both	T	1	-
Cause Light Wounds	Cmbt	T	1	-
Detect Magic	Both	0	All	1t
Protection from Evil	Both	T	1	3r/lvl
Protection from Good	Both	T	1	3r/lvl
Resist Cold	Both	T	1	1t/lvl

SECOND LEVEL CLERICAL SPELLS

SPELL NAME	WHEN	RNG	AREA	DURATION
Find Traps	Camp	3	1	3t
Hold Person	Cmbt	6	1-3 targets	4r+1/lvl
Resist Fire	Both	T	1	1t/lvl
Silence 15' Radius	Cmbt	12	3 dia	2r/lvl
Slow Poison	Both	T	1	1 hour/lvl
Snake Charm	Cmbt	3	All	5-8r
Spiritual Hammer	Cmbt	3	1	1r/lvl

THIRD LEVEL CLERICAL SPELLS

SPELL NAME	WHEN	RNG	AREA	DURATION
Cure Blindness	Both	T	1	-
Cause Blindness	Cmbt	T	1	-
Cure Disease	Camp	T	1	-
Cause Disease	Cmbt	T	1	-
Dispel Magic	Both	6	3x3	-
Prayer	Both	0	All	1r/lvl
Remove Curse	Both	T	1	-
Bestow Curse	Cmbt	T	1	1t/lvl

FIRST LEVEL MAGIC-USER SPELLS

SPELL NAME	WHEN	RNG	AREA	DURATION
Burning Hands	Cmbt	T	3 squares	-
Charm Person	Cmbt	12	1	-
Detect Magic	Both	0	All	2r/lvl
Enlarge	Both	.5/lvl	1	1t/lvl
Reduce	Both	.5/lvl	1	-
Friends	Camp	0	All	1r/lvl
Magic Missile	Cmbt	6+lvl	1	-
Protection from Evil	Both	T	1	2r/lvl
Protection from Good	Both	T	1	2r/lvl
Read Magic	Camp	0	1	2r/lvl
Shield	Both	0	1	5r/lvl
Shocking Grasp	Cmbt	T	1	-
Sleep	Cmbt	3+lvl	1-16	5r/lvl

SECOND LEVEL MAGIC-USER SPELLS

SPELL NAME	WHEN	RNG	AREA	DURATION
Detect Invisibility	Both	0	All	5r/lvl
Invisibility	Both	T	1	-
Knock	Camp	6	1/lvl	-
Mirror Image	Both	0	1	2r/lvl
Ray of Enfeeblement	Cmbt	1+25/lvl	1	1r/lvl
Stinking Cloud	Cmbt	3	2x2	1r/lvl
Strength	Both	T	1	6t/lvl

THIRD LEVEL MAGIC-USER SPELLS

SPELL NAME	WHEN	RNG	AREA	DURATION
Blink	Both	0	1	1r/lvl
Dispel Magic	Both	12	3x3	-
Fireball	Cmbt	10+lvl	2/3 rad	-
Haste	Both	6	5 dia	3r+1/lvl
Hold Person	Cmbt	12	1-4	2r/lvl
Invisibility 10' Radius	Both	T	2 dia	-
Lightning Bolt	Cmbt	4+lvl	4,8	-
Protection from Evil 10'	Both	T	2 dia	2r/lvl
Protection from Good 10'	Both	T	2 dia	2r/lvl
Protection from Normal Missile	Both	T	1	1t/lvl
Slow	Cmbt	9+lvl	5 dia	3r+1/lvl

Level Advancement Tables

The following charts show the amount of experience a character must earn in order to gain a level in his character class. The charts also list the number of spells that a character can have memorized at one time. Fighters and Thieves can never memorize spells.

CLERIC

LEVEL	EXPERIENCE	HIT DICE	NUMBER OF CLERICAL SPELLS PER LEVEL		
			1	2	3
1	0-1,500	1d8	1		
2	1,501-3,000	2d8	2		
3	3,001-6,000	3d8	2	1	
4	6,001-13,000	4d8	3	2	
5	13,001-27,500	5d8	3	3	1
6	27,501+	6d8	3	3	2

CLERIC'S BONUS SPELLS

WISDOM	1	2	3
9-12	-	-	-
13	+1	-	-
14	+2	-	-
15	+2	+1	-
16	+2	+2	-
17	+2	+2	+1
18	+2	+2	+1

Note: These bonus spells are only available when the cleric is entitled to spells of the applicable level. Thus a 4th level cleric with a Wisdom of 18 can memorize the following spells:

4th level Cleric with 18 Wisdom	NUMBER OF SPELLS		
	1	2	3
	5	4	-

Remember that all experience earned by a non-human, multi-class character is divided by the number of classes the character has. The experience is divided even after the character has reached his maximum level in a particular class. A Human dual-class character only earns experience in his second class. The character cannot use the abilities of his first class until his level in his second class exceeds his level in his first class.

FIGHTER

LEVEL	EXPERIENCE	HIT DICE
1	0-2,000	1d10
2	2,001-4,000	2d10
3	4,001-8,000	3d10
4	8,001-18,000	4d10
5	18,001-35,000	5d10
6	35,001-70,000	6d10
7	70,001-125,000	7d10
8	125,001+	8d10

MAGIC-USER

LEVEL	EXPERIENCE	HIT DICE	NUMBER OF MAGIC-USER SPELLS PER LEVEL		
			1	2	3
1	0-2,500	1d4	1		
2	2,501-5,000	2d4	2		
3	5,001-10,000	3d4	2	1	
4	10,001-22,500	4d4	3	2	
5	22,501-40,000	5d4	4	2	1
6	40,001+	6d4	4	2	2

Tables continue...

PALADIN

LEVEL	EXPERIENCE	HIT DICE
1	0-2,750	1d10
2	2,751-5,500	2d10
3	5,501-12,000	3d10
4	12,001-24,000	4d10
5	24,001-45,000	5d10
6	45,001-95,000	6d10
7	95,001-175,000	7d10
8	175,001+	8d10

RANGER

LEVEL	EXPERIENCE	HIT DICE
1	0-2,250	2d8
2	2,251-4,500	3d8
3	4,501-10,000	4d8
4	10,001-20,000	5d8
5	20,001-40,000	6d8
6	40,001-90,000	7d8
7	90,001+	8d8

THIEF

LEVEL	EXPERIENCE	HIT DICE
1	0-1,250	1d6
2	1,251-2,500	2d6
3	2,501-5,000	3d6
4	5,001-10,000	4d6
5	10,001-20,000	5d6
6	20,001-42,500	6d6
7	42,501-70,000	7d6
8	70,001+	8d6

GATEWAY TO THE
SAVAGE FRONTIER

PROOF OF PURCHASE



STRATEGIC SIMULATIONS, INC.

IBM COMPATIBLE COMPUTER INFORMATION:

Many of our games will work on IBM compatible computers. If you own an IBM compatible computer we suggest that you consult with our Technical Support Staff at (408) 737-6850 between 11 a.m. and 5 p.m., Pacific Time, Monday through Friday, (holidays excluded) to see if an SSI game you're considering purchasing is compatible with your computer. If we have insufficient data to determine compatibility, you may wish to purchase the game and test for compatibility yourself. If the game proves to be incompatible, you may return it within 14 days with your dated receipt and we will refund your money. Or, if you return the game within 30 days, you may exchange the game for another.

ADVANCED DUNGEONS & DRAGONS, AD&D and FORGOTTEN REALMS are trademarks owned by and used under license from TSR, Inc., Lake Geneva, WI, USA.

Copyright 1991 Strategic Simulations, Inc. All Rights Reserved.

Copyright 1991 TSR, Inc. All Rights Reserved.

These rules, any accompanying printed material, and the computer programs, on floppy disks or cassettes, described herein, are copyrighted and include proprietary information belonging to Strategic Simulations, Inc. and TSR, Inc. No one is permitted to give or sell copies of this handbook, any accompanying printed material, and the computer programs, on floppy disks or cassettes, or listings of the programs on floppy disks or cassettes to any person or institution except as provided for by written agreement with Strategic Simulations, Inc. and TSR, Inc. No one may copy, photocopy, reproduce, translate, or reduce to machine readable form this handbook or any other accompanying printed material, in whole or in part, without the prior written consent of Strategic Simulations, Inc. and TSR, Inc.

Any person/persons reproducing any portion of this program for any reason, in any media, shall be guilty of copyright violation and subject to the appropriate civil or criminal legal action at the discretion of the copyright holder(s).



STRATEGIC SIMULATIONS, INC.®