

\$9.95

A Shortcut Through Adventureland

VOL. II - INFOCOM

The Complete Guide
To Infocom's Adventures!



by Richard Owen Lynn,
Paul Ashley and Michael W. Sloan

A Shortcut Through Adventureland

VOL. II - INFOCOM

Richard Owen Lynn
Paul Ashley
Michael W. Sloat

Illustrated by
Dorothy Jones

DATANOST

1234567890
1234567890
1234567890

A Shortcut Through Adventureland

VOL. II - INFOCOM

by

**Richard Owen Lynn
Paul Ashley
Michael W. Sloan**

**Illustrated by
Daerick Gross**



DATAMOST

20660 Nordhoff Street
Chatsworth, CA 91311-6152
(818) 709-1202

First Printing, April 1984
Second Printing, September 1984

 **DATAMOST™**

ISBN 0-88190-358-2

**Copyright© 1984 DATAMOST, Inc.
All Rights Reserved**

This book is published and copyrighted by DATAMOST, Inc. All rights are reserved by DATAMOST, Inc. Copying, duplicating, selling or otherwise distributing this product is hereby expressly forbidden except by prior consent of DATAMOST, Inc.

Zork I™, Zork II™, Zork III™, Enchanter™, Starcross™, Suspended™, Planetfall™, Deadline™, The Witness™, and Infidel™ are all registered trademarks of Infocom.

Infocom was not in any way involved with the writing or any other preparation of this book, nor were the facts presented here reviewed for accuracy by Infocom. Use of the name Infocom, or any of its products listed above should not be construed to represent any endorsement, official or otherwise from Infocom.

Printed in U.S.A.

Acknowledgements

Of course, this book would never have been written without Infocom and its programmers. We would also like to acknowledge the contributions of Ruth Ashley who gave us moral support and encouragement, as well as Chapin Day, Jr., who solved Infocom games along with the best of us!

Table of Contents

Introduction to the Book	9
Why (and How) to Use This Book	9
General Infocom Game Hints	11
Zork I	13
Introduction to Zork I	13
General Hints	14
Room Notes	16
How to Win	30
Map	35
Zork II	39
Introduction to Zork II	39
General Hints	40
Room Notes	41
How to Win	52
Map	57
Zork III	59
Introduction to Zork III	59
General Hints	59
Room Notes	60
How to Win	69
Map	72
Enchanter	75
Introduction to Enchanter	75
General Hints	75
Room Notes	76
How to Win	88
Map	92
Starcross	95
Introduction to Starcross	95
General Hints	96

Room Notes	97
How to Win	107
Map	112
Suspended	115
Introduction to Suspended	115
General Hints	117
Room Notes	117
How to Win	126
Map	129
Planetfall	131
Introduction to Planetfall	131
General Hints	131
Room Notes	132
How to Win	147
Map	152
Deadline	155
Introduction to Deadline	155
General Hints	155
Room Notes	156
How to Win	160
Map	163
The Witness	165
Introduction to The Witness	165
General Hints	166
Room Notes	166
How to Win	170
Map	172
Infidel	173
Introduction to Infidel	173
General Hints	173
Room Notes	174
How to Win	184
Map	188

Introduction to the Book

This book is intended as an aid in playing text adventure games produced by Infocom. These games are all complex, requiring a great deal of logic and imagination. They also can produce a great deal of frustration. We hope to help you eliminate some of the frustrations, but let you get the fun out of playing and winning Infocom adventure games.

Infocom has produced several types of text adventure games; this book covers the first 10 of them. They include four "fantasy" games—*Zork I*, *Zork II*, *Zork III*, and *Enchanter*—which are all related, though you can play them in any order. There are two mystery story games—*Deadline* and *The Witness*—that let you discover clues and solve crimes. There are three science-fiction games—*Suspended*, *Starcross*, and *Planetfall*—that let you deal with space and robots. And finally, there is *Infidel*, which takes you to a pyramid in ancient Egypt. Any or all of these games can give you a real challenge and a marvelous game playing experience.

Why (and How) to Use This Book

The level of logic, imagination, memory and puzzle solving skills required to win any Infocom game is very high. Many of us need a hint or a clue at some time. Some people want just a general hint, others want to be able to ask a specific question. Still others want to know all the steps. We have tried to provide something for everyone who is playing Infocom games.

Each of the 10 sections in this book deals with a separate game. Each section contains five parts: a game introduction, general

hints for playing the game, room notes, a detailed list of how to win the game, and a map. Which parts you use depends on how much help you want in winning the game.

The map itself can be a big help. We've included the room numbers on all of the maps. The "how to win" and room notes refer to room numbers. The game itself refers to the names.

The game introduction tells you the purpose of the game, and the general hints tell you what to watch out for in playing it. These can help you get started if you are playing the game for the first time.

The "how to win" section details all the steps needed to win. We suggest you try this as a last resort. The real joy of Infocom games comes from pitting your mind against the challenge of the game itself. But if you're desperate, these steps will help you win. Then, you can go back and play the game for fun!

The room notes give specific information about each location in the game. The listing gives the number (from the map) and the room name (as you'll see it on the screen). You can look up a room when you need a hint. The room notes and map should be enough in many cases to get you through the game. They'll keep frustration down and excitement up until you win.

We love Infocom games! They've challenged and entertained us for hours (and weeks) over the last few years. We anxiously await more and more of them! In writing this book, we hope to share some of the excitement and encourage more people to play them.

General Infocom Game Hints

In most Infocom games, you will need light. If there is a portable light source, you will undoubtedly find it before you enter the dungeon.

The method that Infocom uses to interpret your input is amazing. You can type in a normal sentence and five times out of 10, it will be understood.

Before you do anything really dangerous, you may want to save the game. You can do this by typing "SAVE". To restore the game, type "RESTORE".

Zork I

Introduction to Zork I

Zork I lets you travel to the Great Underground Empire. Here you will have adventures, suffer, succeed and ultimately find your way to the beginning of *Zork II*.

To win the game, you have to discover treasures and bring them to the trophy case located in room #20. In the process, you will accumulate up to 350 points for such events as solving puzzles, exploring new areas, and simply bringing treasures to the trophy case. You can find out your general adventure ability with *Zork* by checking your score from time to time. You will have won when you find the way to the stone barrow. Here is a list of treasures you will need to successfully complete *Zork*.

- Torch
- Canary
- Sceptre
- Pot of gold
- Bauble
- Diamond
- Coffin
- Scarab
- Chalice
- Egg
- Figurine
- Skull
- Emerald
- Bracelet
- Trident
- Trunk of jewels
- Bar
- Bag of coins
- Painting

General Hints

In most rooms in *Zork I* you will need a light source (to see and protect yourself from grues). The first light source you will probably find is the lamp. It will usually work for a sufficient amount of time, but if it happens to run out, there are alternatives—for instance, candles. Unfortunately, they really don't last very long, and they can be blown out by wind in the caves. The best light source would probably be the torch. It can't be put out no matter how hard you try, and it will never burn out. However, there are some disadvantages—it can't be taken below the gas room unless the bat takes you there or you have enclosed the torch in something. In addition, if you are only carrying the torch, the thief may come take it from you, in which case you would be left without a light source. We suggest you use the torch as a light source after you find it, you'll need to use the lamp when getting the diamond. If you haven't killed the thief yet, we suggest you keep the torch in something open—for instance, carry the boat and put the torch in it.

Another problem you may come across when playing *Zork* is that you are limited in the number of objects you can carry. We have found ways around this problem, although the solutions appear to be errors in programming rather than true solutions. The simplest solution we have found is to carry the boat everywhere you go, and instead of saying "GET object," say "PUT object IN BOAT." When you do this, *Zork* will still say your load is too heavy, but it will allow you to collect the objects anyway.

There are some restrictions on objects.

- You can't take the torch or candles into the gas room.
- You can't put the sceptre in the boat.
- After you squeeze the gunk into your hands, you can't put it back into the tube.
- Once your lamp runs out, you can't recharge it.
- The candles might blow out in the caves.
- The timber isn't useful for anything.
- You can't go up the ramp.

- Nothing fits through the crack to the coal compressor.
- To go up the chimney, you must have the lamp and one other object.
- Openable objects (except for the trophy case) have a limit on how much they hold.
- There are 69,105 leaves, no more, no less.
- There are only five matches, no more.
- The sword is a very large object; up to four or five times heavier than some other objects.
- If you try to fight with the rusty knife, it will kill you.
- You can't light the candles with the torch.
- You can't get the vitreous slag.

You can't get by the troll until you kill him or knock him out. Killing him seems to work best; that way you will only encounter him once. The sword seems to work best for killing the troll, and the nasty knife seems to work best for knocking him out.

You will also have to kill the thief, whom you will meet from time to time. The nasty knife works best against him. If you happen to kill the thief before the troll you can't use the stiletto against the troll.

You can't kill the cyclops, so don't worry about what to use against him.

Room Notes

1. **West of house**—The mailbox contains an ad for Infocom. It will not help you win the game. The path leading southwest from here will only be here after you have put all the treasures into the trophy case.

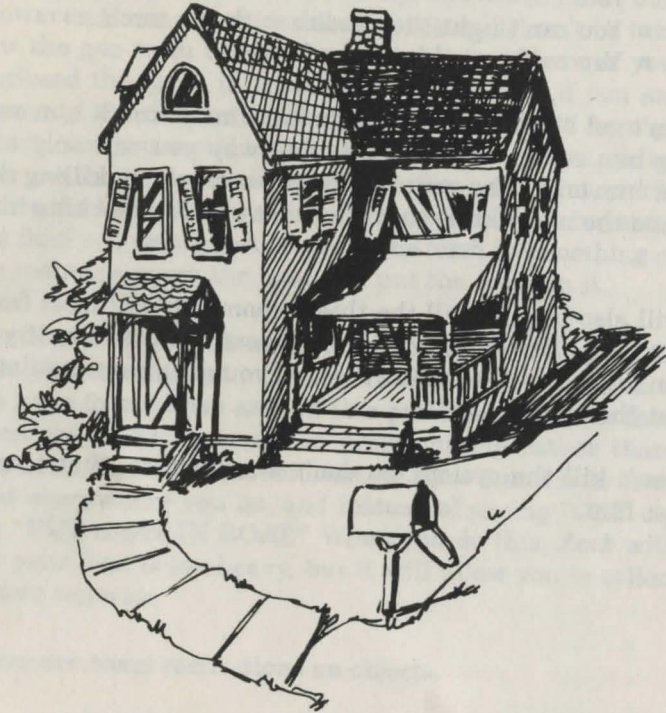

2. **North of house**—There is nothing to do here.
3. **East of house**—Open window and go west to enter the house.
4. **South of house**—There is nothing to do here.

5. **Forest**—You end up here when you die, but there is nothing to do here.
6. **Forest path**—Climb the tree to get the egg.
7. **Forest**—There is nothing to do here.
8. **Forest**—There is nothing to do here.
9. **Clearing**—The pile of leaves is not important. If you move it, you will see a grating. The grating can only be unlocked from the inside. You need the skeleton key (room #31). The key and the lock are in the maze. The grating leads to room #45, but don't bother; there are better ways.
10. **Forest**—There is nothing to do here.
11. **Forest**—There is nothing to do here.
12. **Canyon view**—There is nothing to do here.
13. **Rocky ledge**—There is nothing to do here.
14. **Canyon bottom**—There is nothing to do here.
15. **End of rainbow**—A pot of gold appears after you wave the sceptre. The sceptre is very deep in the Great Underground Empire (room #60). Come back here when you have it. Once you have waved the sceptre, you can go east, on to the rainbow.
16. **On the rainbow**—You are now on the rainbow. If you go east, be sure you have a light source. Don't wave the sceptre up here; it will cause the rainbow to disappear.
17. **Up a tree**—Take the egg. Do not try to open it or it will be destroyed. The only person who can open the egg is the thief. Inside the egg is a beautiful canary. Wind it up in the forest, and it will chirp. A songbird will then come and drop a brass bauble. You get three treasures for the price of one.

18. **Kitchen**—Open the sack. The garlic will be needed in room #83. The hot pepper sandwich and the water are not necessary, but you can use them to get past the Cyclops in room #46.

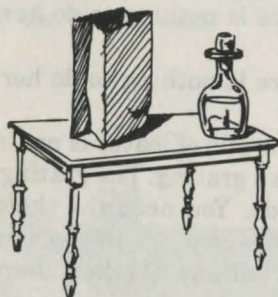

19. **Attic**—The knife should be used to kill the thief. The rope can be used in room #57.

20. **Living room**—The sword should be used to kill the troll in room #25. When you get treasures, you should put them in the trophy case. Move the rug, and you will see a trap door. Open it. Before you go down, you should get the lamp. Turn the lamp on. Now go down.

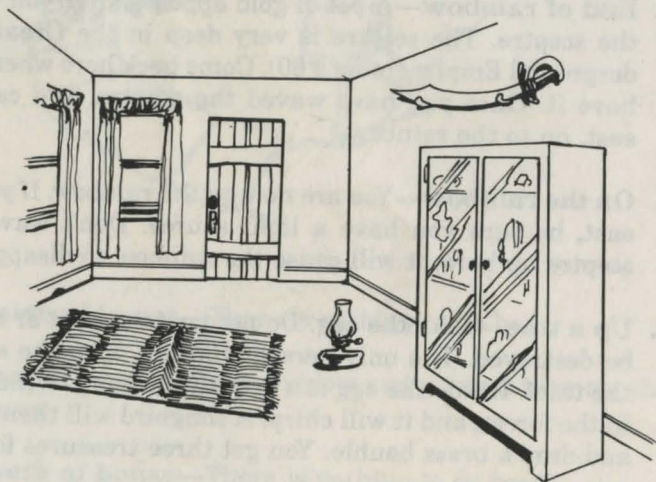

21. **Cellar**—You cannot go up the ramp. You cannot go back up the trap door until you have found a way out besides dying and the chimney in room #24.

22. **East of chasm**—There is nothing to do here.

23. **Gallery**—The painting is a treasure. Take it and put it in the trophy case.

24. **Studio**—You can go up the chimney, but you must have the lamp and one other item. There are other ways out, but you can use this to begin with.

25. **Troll room**—The sword (room #20) is most useful in killing the troll. If you knock him out, kill him so he won't bother you later. He must be unconscious or dead before you can pass.



26. **Maze**—There is nothing to do here.
27. **Maze**—There is nothing to do here.
28. **Maze**—There is nothing to do here.
29. **Maze**—There is nothing to do here.
30. **Dead end**—There is nothing to do here.
31. **Maze**—There is a skeleton here. Leave it alone if you value your life. There is a rusty knife here. If you try to use it, it comes back at you and slits your throat. There is a skeleton key here. It will only open the grating (room #45). Finally, there is a bag of coins here. It is a treasure, so take it.
32. **Maze**—There is nothing to do here.
33. **Maze**—There is nothing to do here.
34. **Maze**—There is nothing to do here.
35. **Maze**—There is nothing to do here.
36. **Maze**—There is nothing to do here.
37. **Maze**—There is nothing to do here.
38. **Maze**—There is nothing to do here.
39. **Maze**—There is nothing to do here.
40. **Maze**—There is nothing to do here.
41. **Maze**—There is nothing to do here.
42. **Maze**—There is nothing to do here.
43. **Maze**—There is nothing to do here.

44. **Maze**—There is nothing to do here.
45. **Grating room**—This is the location of the grating. It is opened with the skeleton key (room #31). This grating leads up to room #9.
46. **Cyclops room**—There is a cyclops here. There are two ways to avoid him. Either give him the lunch and water (from the room #18), or say "ODYSSEUS" ("ULYSSES" will work, too). Talking to him usually works better, because not only does he leave for good, but he opens up a passage leading to room #20. Otherwise, he will just fall asleep at the bottom of the stairs. If you talk to him, the name of the room might change after a while. Don't worry, it happens all the time.



47. **Strange passage**—This passage will only be here if you talk to the cyclops.

48. **Treasure room**—The thief will always come here when you enter, unless he's dead. Come here to kill him, or he will leave when he gets seriously injured. You must come here to kill him sooner or later. The more points you have when you come, the harder it is for you to get killed. Hint: the nasty knife seems to work best against him. Since the thief is the only one who can open the egg (room #17), you will want to give it to him before you (hopefully) kill him. Giving treasures to the thief is OK, because you can get them back when he dies. When you give him a treasure, he is off his guard, and that gives you a chance to attack. If, by chance, you knock him out, don't bother trying to take the stiletto. Not only can't you take it, but it isn't good for anything. Even if you only knocked out the troll, you can't use the stiletto to kill him.
49. **East-west passage**—There is nothing to do here.
50. **Round room**—There is nothing to do here.
51. **Narrow passage**—There is nothing to do here.
52. **Mirror room**—If you touch the mirror here, it transports you to the other mirror room (room #78).
53. **Winding passage**—There is nothing to do here.
54. **Cave**—The wind here might blow out the candles. There is a one-way passage here from room #60.
55. **Entrance to Hades**—To get into room #62 from here, you will need a few things. First of all, you will need the book (room #61). The book gives you the instructions on how to get in, but we'll tell you, too. You will need the book, the candles (room #61), and the bell (room #59). Put down the candles, to save time. Ring the bell. If you didn't drop the candles, they will have dropped to the ground and will be out. Don't give up hope, because you can still get the matches from room #70. Get (or light) the candles, then read the book. You may now go south to room #62.

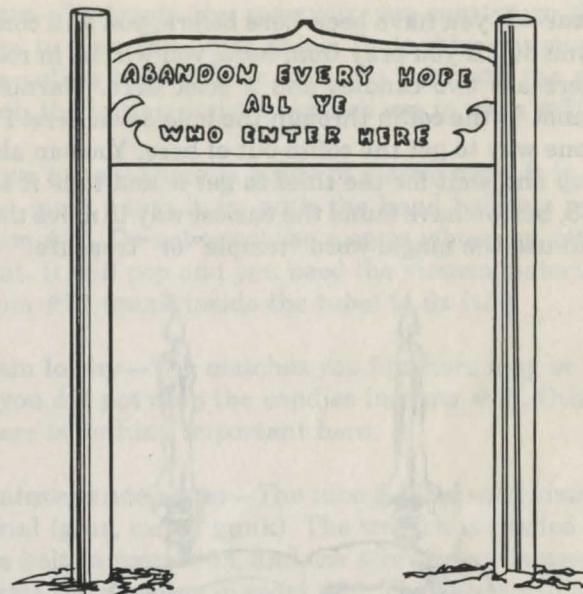

56. **Engravings room**—There is nothing to do here.
57. **Dome room**—If you are dead, you will be automatically transported from here to room #58. If not, you must take the rope from room #19, and tie it to the railing. Then you can go down.
58. **Torch room**—There is a torch here. It is a treasure. It is also a good light source. It is also very helpful in getting a treasure. The explanation is in room #84.
59. **Temple**—One of the walls in here is granite. You can say "temple" or "treasure" to get to room #48. That word will get you back, too. There is a bell here. It is needed in room #55.
60. **Egyptian room**—There is a solid gold coffin here. It is obviously a treasure. There is a sceptre in the coffin, which is also a treasure. It should be taken to room #20. It can be used in rooms #15, #16, and #109. It should not, however, be used in room #16.

61. **Altar**—If you have been here before, you will come here if you die. If you pray from here, you will be in room #5. There are two candles and a book here. Warning: you cannot fit the coffin through the hole down here. Praying is one way to get the coffin out of here. You can also pick it up and wait for the thief to get it and take it to room #48, but we have found the easiest way to move the coffin is to use the magic word “temple” or “treasure.”

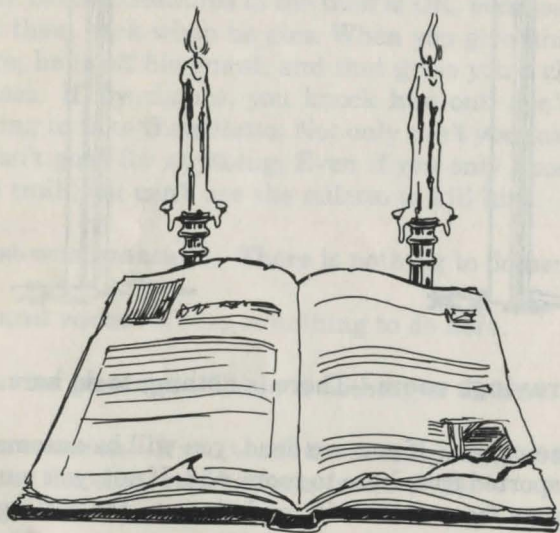

62. **Land of the dead**—There is a crystal skull here. It is a treasure. Take it up to room #20.
63. **North-south passage**—There is nothing to do here.
64. **Chasm**—There is nothing to do here.
65. **Deep canyon**—There is nothing to do here.
66. **Reservoir south**—You can only cross here after you let the water out. An explanation of how to do this is in room #68.
67. **Stream view**—There is nothing to do here.

68. **Dam**—To empty the reservoir, you must turn the bolt here to open the sluice gates. To do this, you must push the yellow button, then turn the bolt with the wrench. Both the button and the wrench are in room #71.
69. **Dam base**—There is a pile of plastic here. It is a boat. You must pump it up with the hand held air pump in room #74. Do not carry the sceptre when you get in the boat. It will pop and you need the viscous material from room #71 (gunk inside the tube) to fix it.
70. **Dam lobby**—The matches you find here may be needed if you did not drop the candles in room #55. Otherwise, there is nothing important here.
71. **Maintenance room**—The tube is filled with viscous material (glue, called gunk). The wrench is needed to turn the bolt in room #68, and the screwdriver is used to activate the machine in room #96. The chests will crumble at your touch.

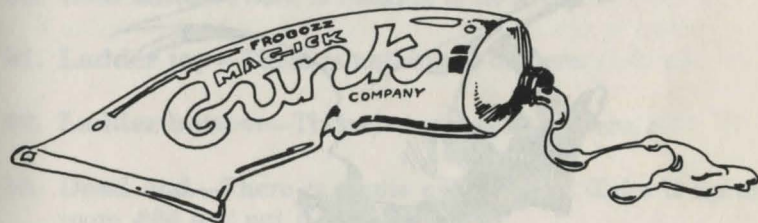

72. **Reservoir**—There is a trunk of jewels here, unless you are here before emptying the reservoir or after refilling it (in the boat, I hope). It is a treasure. Take it to room #20.
73. **Stream**—There is nothing to do here.
74. **Reservoir north**—There is an air pump here. It is necessary to inflate the pile of plastic (boat in room #69).

75. **Atlantis room**—There is a crystal trident here. It is a treasure. Take it back to the trophy case.
76. **Cave**—There is nothing to do here.
77. **Twisting passage**—There is nothing to do here.
78. **Mirror room**—Touch the mirror to get to room #52.
79. **Cold passage**—There is nothing to do here.
80. **Slide room**—The granite wall isn't granite. The slide leads down to room #21, but you will not be able to get back up.
81. **Mine entrance**—There is nothing to do here.
82. **Squeaky room**—This is a hint that there is something in the next room, which there is.



83. **Bat room**—There is a bat here (making squeaky noises). Since he is a reject from WUMPUS, he likes to pick you up and take you away, usually to someplace in the coal mine. The way to avoid this problem is to make sure you have some garlic with you whenever you go into the room. The garlic can be found in the sack in room #18. We found it easiest to drop the garlic in the room so it will always be there and you don't have to carry it everywhere you go.

84. **Shaft room**—There is a basket on a chain here. It leads down to room #95. It must be used to get the diamond. You must put the torch (or candles), the screwdriver (room #71), and the pile of coal (room #93), in the basket; then lower it and continue down to room #94 for more directions.
85. **Smelly room**—This is a clue that there is something below you. It happens to be coal gas, so don't bring a flame into the next room, unless you have a thing for dying.
86. **Gas room**—You may not have a flame in this room. There is a bracelet in here, which is a treasure; take it to room #20.
87. **Coal mine**—These rooms are somewhat of a maze.
88. **Coal mine**—There is nothing to do here.
89. **Coal mine**—There is nothing to do here.
90. **Coal mine**—There is nothing to do here.
91. **Ladder top**—There is nothing to do here.
92. **Ladder bottom**—There is nothing to do here.
93. **Dead end**—There is a pile of coal here. Take it up to room #84 and put it in the basket.



94. **Timber room**—You do not need the timber for anything. To go west from here, you must drop everything. Leave the lamp on. If you turn it off, you will not be able to turn it on when you get out. Make sure the basket is lowered, or you will not be able to do anything.
95. **Drafty room**—You must get everything out of the basket and go south to room #96; then follow those directions. After you are done, come here and put everything back in the basket (although you really don't need the screwdriver for anything else).
96. **Machine room**—Open the machine, put the coal in it, close the lid, and flip the switch with the screwdriver. The coal will not be in the machine anymore, but open it to find a huge diamond.
97. **Loud room**—There are two ways to get the platinum bar here. The easiest way is to say "echo." The acoustics of the room change subtly, and you can hear yourself. The other way is very complicated. You must open the dam (room #68), and wait until all the water flows out, then close it again, and you will be able to pick up or drop anything for about 10 turns.
98. **Damp cave**—There is nothing to do here.
99. **White cliffs beach**—There is nothing to do here.
100. **White cliffs beach**—There is nothing to do here.
101. **Frigid river**—There is nothing to do here.
102. **Frigid river**—There is nothing to do here.
103. **Frigid river**—There is nothing to do here.
104. **Frigid river**—There is a red buoy here. It is closed. There is an emerald in it. Open it and get the emerald. Be careful, you only have two turns here, because the water carries you downstream.

105. **Frigid river**—If you get here, land; otherwise you will go down the falls. It is a long drop; too long, in fact.
106. **Sandy beach**—There is a shovel here. Take it to room #107 and follow the directions.
107. **Sandy cave**—Dig the ground here four times and there will be a scarab in the sand. It is a treasure; take it to room #20.
108. **Shore**—There is nothing to do here.
109. **Aragain falls**—You can wave the sceptre (room #67) here and the rainbow will become solid.



110. **Stone barrow**—The passage leading to here only exists if you have gotten all the treasures into the trophy case. Just go west to win.

How to Win

- Go to room #17.
- Get the egg.
- Go to room #3.
- Open the window.
- Go to room #20.
- Get all.
- Move the rug.
- Open the trap door.
- Open the case.
- Go to room #23.
- Get the painting.
- Go to room #25.
- Kill the troll.
- Drop the sword.
- Go to room #33.
- Get the bag.
- Go to room #46.
- Say "ODYSSEUS" (or "ULYSSES").
- Go to room #20.
- Put the painting, egg, and bag in the case.
- Open the trap door.
- Go to room #99.
- Say "ECHO."
- Get the bar.
- Go to room #52.
- Touch the mirror (to room #78).
- Go to room #75.
- Get the trident.
- Go to room #74.
- Get the pump.
- Go to room #78.
- Touch the mirror (to room #52).
- Go to room #69.
- Inflate the boat with the pump.
- Put the trident and bar in the boat.
- Go to room #71.
- Get the wrench and screwdriver.
- Push the yellow button.

- Go to room #68.
- Turn the bolt with the wrench.
- Drop the wrench.
- Go to room #69.
- Get in the boat.
- Say "LAUNCH."
- Say wait ten times.
- Get the buoy.
- Go east (to room #106).
- Get out of the boat.
- Get the shovel.
- Go to room #107.
- Dig the sand four times.
- Drop the shovel.
- Get the scarab.
- Go to room #106.
- Open the buoy.
- Put the emerald and scarab in the boat.
- Drop the buoy.
- Get in the boat.
- Say "LAUNCH."
- Go west (to room #100).
- Get out of the boat.
- Deflate the boat.
- Get the boat.
- Go to room #20.
- Drop the boat.
- Inflate the boat with the pump.
- Put the scarab, emerald, trident, and bar in the case.
- Get the boat.
- Go to room #47.
- Say "TEMPLE" (to room #59).
- Go to room #58.
- Put the torch in the boat.
- Go to room #60.
- Open the coffin.
- Get the sceptre.
- Put the coffin in the boat.
- Go to room #61.
- Say "PRAY" (to room #5).
- Go to room #20.

- Drop the lamp.
- Put the coffin in the case.
- Go to room #15.
- Wave the sceptre.
- Put the pot in the boat.
- Go to room #20.
- Get the egg.
- Put the sceptre and pot in the case.
- Go to room #19.
- Get the knife.
- Go to room #47.
- Give the egg to the thief.
- Kill the thief with the knife until he is dead.
- Drop the knife.
- Put the chalice, egg, and canary in the boat.
- Go to room #6 (or #5, #8, #9, #10, or #17).
- Wind the canary.
- Get the bauble.
- Go to room #20.
- Put the chalice, egg, canary, and bauble in the case.
- Get the lamp.
- Go to room #18.
- Open the sack.
- Put the garlic in the boat.
- Go to room #47.
- Say "TEMPLE" (to room #59).
- Put the bell in the boat.
- Go to room #61.
- Put the book and candles in the boat.
- Go to room #55.
- Ring the bell.
- Get the candles.
- Read the book.
- Drop the candles and book.
- Go to room #62.
- Put the skull in the boat.
- Go to room #52.
- Touch the mirror (to room #78).
- Go to room #72.
- Put the trunk in the boat.
- Go to room #82.

- Get the garlic.
- Go to room #83.
- Drop the garlic.
- Put the figurine in the boat.
- Go to room #84.
- Put the screwdriver and torch in the basket.
- Light the lamp.
- Go to room #86.
- Put the bracelet in the boat.
- Go to room #93.
- Put the coal in the boat.
- Go to room #84.
- Put the coal in the basket.
- Lower the basket.
- Go to room #94.
- Drop all.
- Go to room #95.
- Get all out of the basket.
- Go to room #96.
- Open the lid.
- Put the coal in the machine.
- Close the lid.
- Flip the switch with the screwdriver.
- Open the lid.
- Get the diamond.
- Go to room #95.
- Put the torch and diamond in the basket.
- Drop the screwdriver.
- Raise the basket.
- Go to room #94.
- Get all but the timber.
- Go to room #84.
- Put the torch and diamond in the boat.
- Go to room #80.
- Go down (to room #21).
- Go to room #20.
- Put the torch, skull, diamond, figurine, bracelet, and trunk in the case.
- Go to room #110.
- Go west.
- You have now won *Zork I*.



**Zork I
Above Ground**

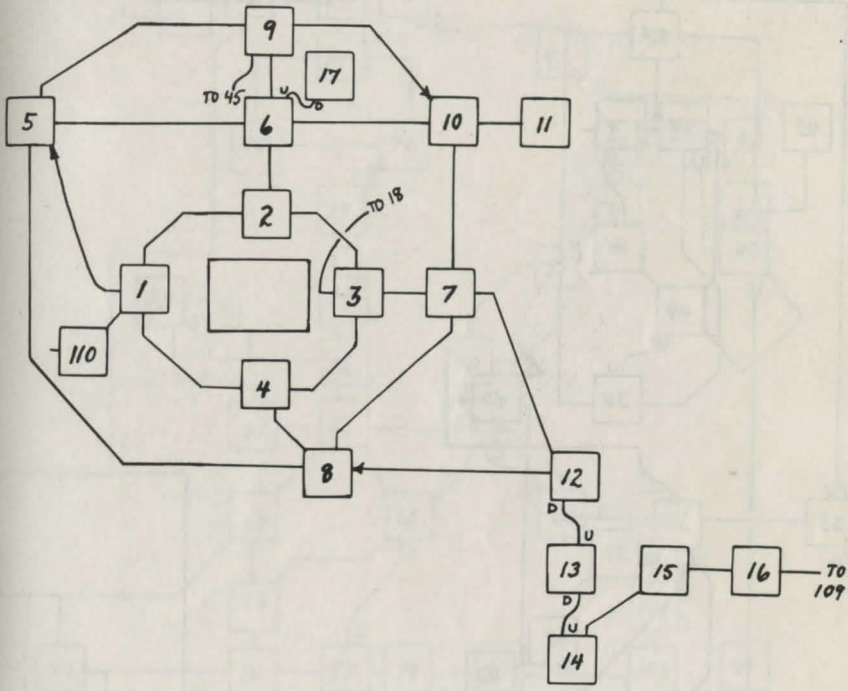

Zork I Underground

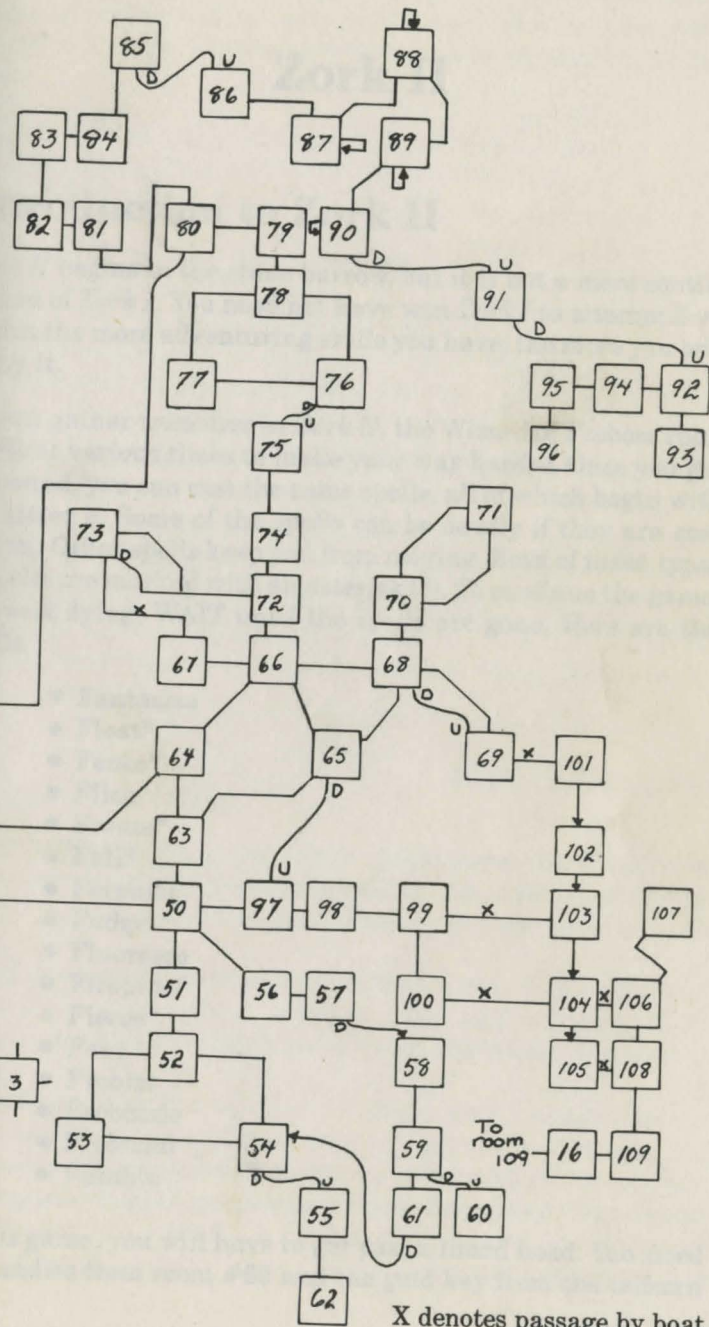
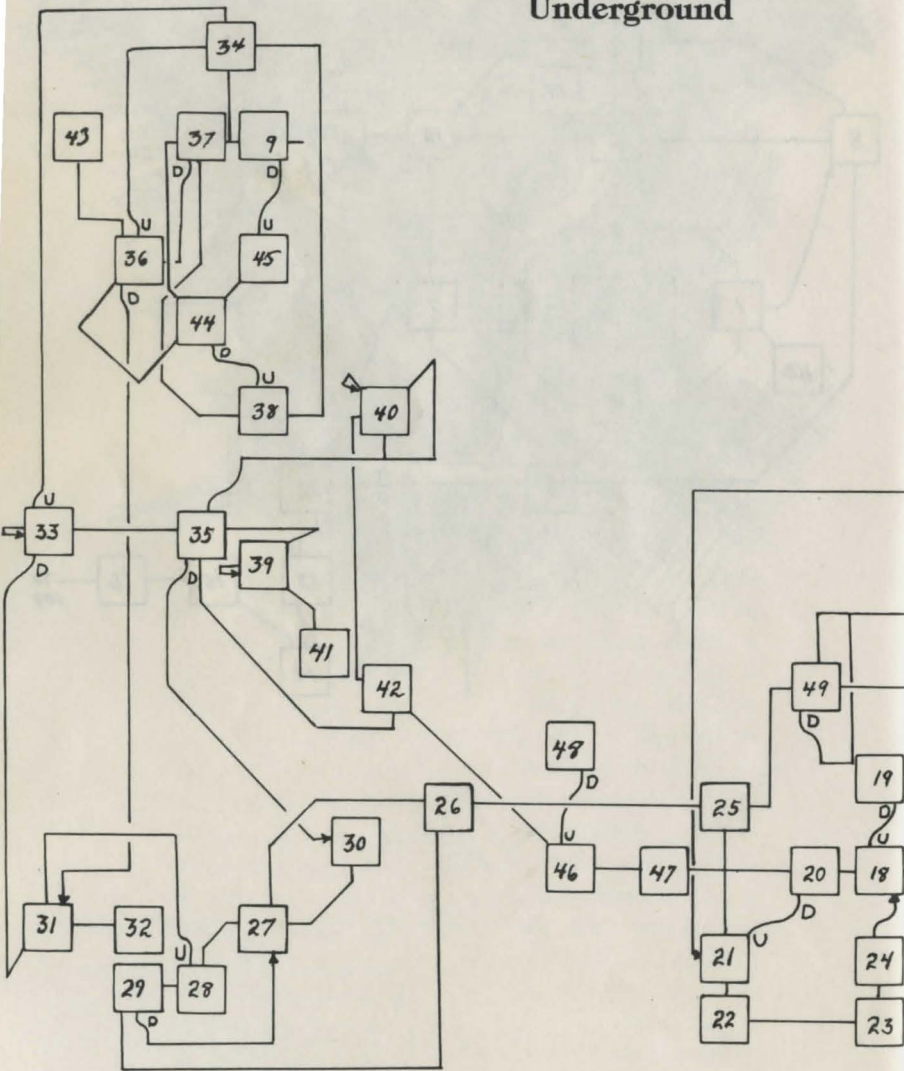

X denotes passage by boat only

Zork II

Introduction to Zork II

Zork II begins in the stone barrow, but it is not a mere continuation of *Zork I*. You need not have won *Zork I* to attempt *Zork II*, but the more adventuring skills you have, the more you will enjoy it.

As you gather treasures in *Zork II*, the Wizard of Frobozz casts spells at various times to make your way harder. Once you get the wand, you can cast the same spells, all of which begin with the letter F. Some of the spells can be deadly if they are cast on you. Other spells keep you from moving. Both of these types of spells are marked with an asterisk (*). To continue the game, or avoid dying, WAIT until the spells are gone. Here are the spells:

- Fantasize
- Float*
- Fence*
- Filch
- Freeze*
- Fall*
- Ferment
- Fudge
- Fluoresce
- Fireproof
- Pierce*
- Fear
- Frobizz
- Frobozzle
- Frobnoird
- Fumble

In this game, you will have to get past a lizard head. You need the candies from room #60 and the gold key from the unicorn

in room #7. Once past this door, you will eventually make the demon appear. He will want the treasures. These are the treasures that you'll have to give to the demon:

- Gold key
- Bills
- Portrait
- Zorkmid
- Rare stamp
- Gaudy crown
- Pearl Necklace
- Stradivarius violin
- Statuette
- Moby ruby

If you have a treasure when you die, you will not have to give it to the demon. Also, if the wizard casts the filch spell on you, the treasures that you touch during the spell will not be necessary (or possible) to give to the demon to complete the game. They will be in the trophy case in room #49.

General Hints

You will always want to be careful when entering multiple commands with periods, or "then," because the wizard can show up at any time and cast a spell, such as FALL.

If possible, you will usually want to solve the tea room area first. By completing this section of the puzzle first, you can stop the carousel, which can throw you off course while running.

In most locations here, as in *Zork I*, you will need to have a light source, but the only one in *Zork II* is a lamp. Use the lamp sparingly, turning it off where it isn't really necessary. Once you get the wizard's wand from the demon, fluoresce something lightweight and not needed, i.e., the perfect rose or the bank brochure.

There is one very important thing you have to remember when you are about to finish this game. When you go to the landing, make sure you have the wand with you; if you don't, you will die.

If you are going to die, you will definitely lose 10 points; but if you die, make sure it is before you free the demon by putting the black sphere in the circle.

You don't want to stay anywhere too long. If you stay in the topiary too long, the bushes will kill you. If you stay in the small room or vault too long, the curtain will close. If you stay in the balloon too long, you will die at the top of the volcano. If you stay on the small ledge too long, it falls down with you on it. If you stay in the wizard's quarters too long, the description of the room changes, although you do not have to worry about that.

When you die, you will be in a red sphere. Go west, and you will be in a blue sphere. Go west again, and you will be in a clear sphere. Go west one more time, and you will be in a black sphere. If you have not yet released the demon, or if this is not your third death, you will be reincarnated. Otherwise, your game will be over.

Room Notes

1. **Inside the barrow**—The lamp is your only light source right now. Take it and use it. The sword is only useful with the dragon in room #19. In fact, it is necessary there.
2. **Narrow tunnel**—There is nothing important here.
3. **Foot bridge**—There is nothing important here.
4. **Great cavern**—There is nothing important here.
5. **Shallow ford**—This is one place to get water needed for room #56/57.
6. **Dark tunnel**—There is nothing important here.

7. **North end of garden**—To enter the gazebo, say either “ENTER GAZEBO” or “IN” or “GO IN.” Very often, there is a unicorn here. It has a gold key around its neck. The only way to get the key is by saving the princess in room #20. Leave the unicorn alone until then, you cannot do anything yet.



8. **Gazebo**—The letter opener and the placemat are needed to get into room #36. The newspaper is needed in room #6; the matches are needed in rooms #36 and #44. The teapot is needed to carry the water for room #56/57.



9. **Formal garden**—There is nothing important here.
10. **Path near stream**—The only way to open the western passage is to free the princess in room #20, and follow her. The passage will stay open.
11. **Topiary**—Nothing is important here, but if you stay around, the animals move. This is not to be taken lightly. If you stay here too long, they will kill you. If, you go back and forth into this room, you will also die.
12. **Carousel room**—This room spins continually until you turn it off in room #62. When you turn it off, a box will fall. Open it, and there will be a Stradivarius violin. Take it down to room #51 if you can, or take it to room #47.



13. **Marble hall**—The brick is necessary to get the crown in room #44. To open the eastern passage, you must free the princess in room #20, and follow her.

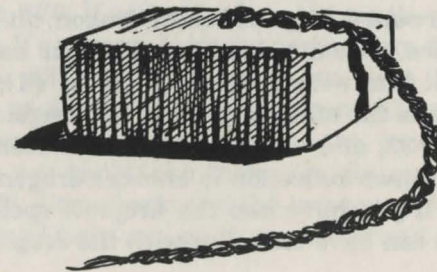

14. **Deep ford**—This is one place to get water for room #56/57.
15. **Ledge in ravine**—There is nothing important here.
16. **Tiny room**—To open the door, you must put the placemat (room #8) under the door, open the lid, and put the letter opener (room #8) in the keyhole. An iron key will appear. Then get the placemat, get the letter opener, unlock the door with the iron key, and open the door. You may now drop the placemat, letter opener, and iron key; they have no other use. It sometimes helps to drop all before you start, and get the things back when you are done, in case you drop something in the process of opening the door (like when you get the placemat and the letter opener).
17. **Dreary room**—The blue sphere is needed in room #50. If you cannot get there yet, leave the sphere in room #47.
18. **End of ledge**—There is nothing important here.

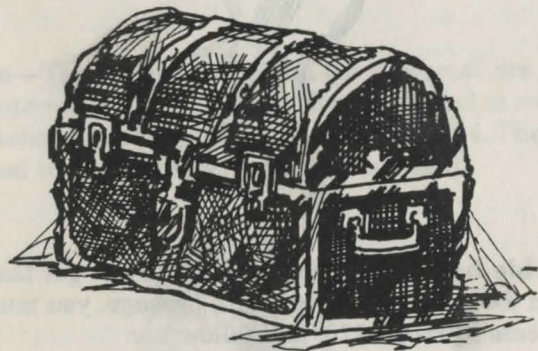

19. **Dragon room**—To get rid of the dragon, hit him with your hands once, go south, hit him with your hands again, go south, hit him with your sword (room #1), and go west. All this has the effect of getting the dragon to follow you to room #32, and, since he has never seen a mirror, he thinks his own reflection is another dragon, and he kills himself. If you have had the fireproof spell cast on you, then you can have some fun with the dragon.

20. **Dragon's lair**—This room has nothing to do with the popular arcade game of the same name. The chest usually has to be opened twice before it is open. The first time you try, the princess will awaken. When the princess leaves, follow her until she rides the unicorn away. When she does this, she will give you a rose, and a key. The rose is romantic, but useless, but the key is needed in room #47. Get the statuette if the chest is open and the princess is still here. Take the statuette to either room #51 or #47.
21. **Cool room**—There is nothing important here.
22. **Fresco room**—There is nothing important here.
23. **Bank entrance**—There is nothing important here.
24. **West teller's room**—There is nothing important here.
25. **East teller's room**—There is nothing important here.
26. **West viewing room**—You can get here through the curtain of light if you came into room #28 from the west. You can return to room #28 by walking through the east wall.
27. **East viewing room**—You can get here through the curtain of light if you came into room #28 from the east. You can return to room #28 by walking through the west wall.
28. **Safety depository**—The curtain of light is a magical doorway. To walk through it, say "WALK THROUGH CURTAIN." If you come in from the east, and walk through the curtain of light, you will go to room #27. If you come from the west, and walk through the curtain of light, you will go to room #26. If you come from the south, you will go to room #30. If you come from the north (room #30), you will go to room #31. To get treasures out, drop them in here, go east or west twice, get the treasures, and walk through the curtain. In other words, leave the treasures here at first since you can't take them straight out. Go to room #26 or #27. Come back. Get the treasures. Walk through the curtain of light and go to room #23 and away.

29. **Chairman's office**—The painting is a treasure. To get it out, follow the directions in room #28.
30. **Small room**—To get out, walk through the south wall. You must come here to get to room #31.
31. **Vault**—Get the bills, and walk through the north wall. Follow the instructions for room #28 to get the bills out.
32. **Ice room**—If you have killed the dragon, you will be able to go east.
33. **Lava tube**—There is nothing important here.
34. **Volcano view**—There is nothing important here.
35. **Lava room**—The moby ruby is a treasure. Take it to room #51 if you can, #47 if you can't.
36. **Volcano bottom**—The cloth bag is a balloon. To inflate it, get in the basket, open the receptacle, put the newspaper in the receptacle, light a match, and burn the newspaper with the match. This will make the balloon go up. To make the balloon go down, close the receptacle.

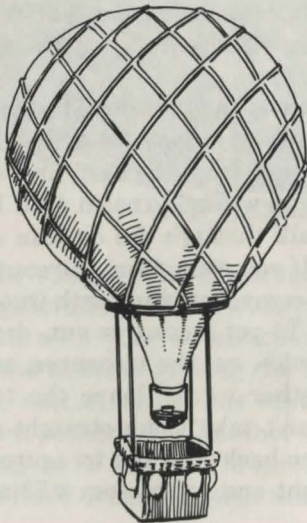

37. **Volcano core**—There is nothing important here.
38. **Volcano near small ledge**—To land the balloon, say "LAND."
39. **Small ledge**—Tie the wire to the hook to keep the balloon from flying away. Untie it when you are ready to leave. The zorkmid is a treasure. Take it.
40. **Library**—Open the purple book and get the stamp. The stamp is a treasure. The other books are useless, even though the white book has information about magic.
41. **Volcano by viewing ledge**—There is nothing important here.
42. **Volcano near wide ledge**—To land the balloon, say "LAND."
43. **Wide ledge**—Tie the wire to the hook to keep the balloon from flying away. Untie it when you are ready to leave.
44. **Dusty room**—Put the string (room #46) in the brick (room #13). Put the brick in the hole in the box on the wall. Light a match (room #8). Burn the string with the match. Go north. Go south. Get the crown. Go back to the balloon and get in. Close the receptacle until you land.
45. **Room 8**—You can only get here if you have turned off the carousel room (room #12) in room #62. The can is needed in room #70 to win. This room is also in *Zork III*.
46. **Cobwebby corridor**—The string is needed in room #44.
47. **Guarded Room**—To get the door open, feed the candies from room #60 to the head, unlock the door with the golden key from the princess, and open the door. Bring all treasures you have collected so far to room #51, except the spheres, which should be brought to room #50.
48. **Wizard's Workshop**—There is nothing important here.



49. Trophy Room—Inside the trophy cabinet are all of the treasures the wizard has filched from you, or that you have had when you died. The treasures cannot be taken by ordinary means, but once you have the wizard's wand, you can **FILCH** them (i.e., point the wand at the treasure case and say 'SAY "FILCH"'). This gets you no points.

50. Wizard's workshop—The red sphere (room #63) should be put on the ruby stand, the clear sphere (room #52) on the diamond stand, and the blue sphere (room #17) on the sapphire stand. Once you have done all this, a black sphere will appear. Take the black sphere to room #51, and follow the directions there.

51. Pentagram room—Put the black sphere in the circle. Give all the treasures (except, of course, the spheres and the candies) to the demon. Once you have done that, say 'TELL DEMON "GIVE ME WAND"', and get the wand. Now go to room #64. If the demon is not satisfied, you probably have forgotten to give him one of the treasures. The three most forgotten treasures are the painting in room #29, the golden key from the princess, and the statuette in room #20.

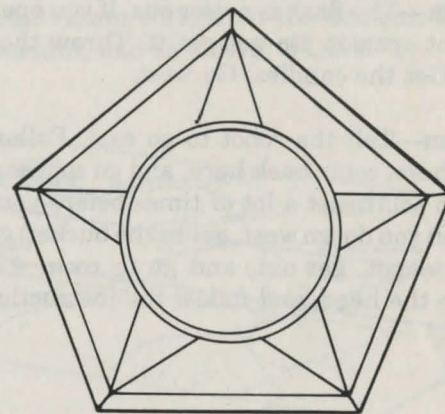

52. Aquarium room—Extinguish the lamp, then throw it at the glass. Get the lamp and the clear sphere. Turn the lamp back on, and take the sphere to room #50.

53. Wizard's quarters—Nothing is important here, but if you look around several times, you will see a new description each time. This is meaningless.

54. Riddle room—To answer the riddle, say 'SAY "WELL"'. You can now go east. You will not have to answer the riddle again, as the door stays open.

55. Pearl room—The necklace is a treasure. Take it.

56. Circular room—Make sure you have the teapot (room #8), and make sure it has water from one of the two places (rooms #5 and #14). Get in the bucket and pour the water. You are now in room #57.

57. **Top of well**—Get out of the bucket and go east.
58. **Tea room**—Get all the cakes except the orange one. If you eat the orange cake, you will explode. Eat the green cake in this room. You are now in room #59.
59. **Posts room**—Go east, follow the directions, come back, and eat the blue cake.
60. **Pool room**—The flask is poisonous. If you open it, you will die. Do not open it. Do not get it. Throw the red cake in the pool. Get the candies. Go west.
61. **Low room**—Tell the robot to go east. Follow all the directions there, come back here, and go southeast. You may have to go southeast a lot of times before you get to room #58. When you do, go west, get in the bucket, get the water, drop the teapot, get out, and go to room #47. Give the candies to the head, and follow the instructions there.

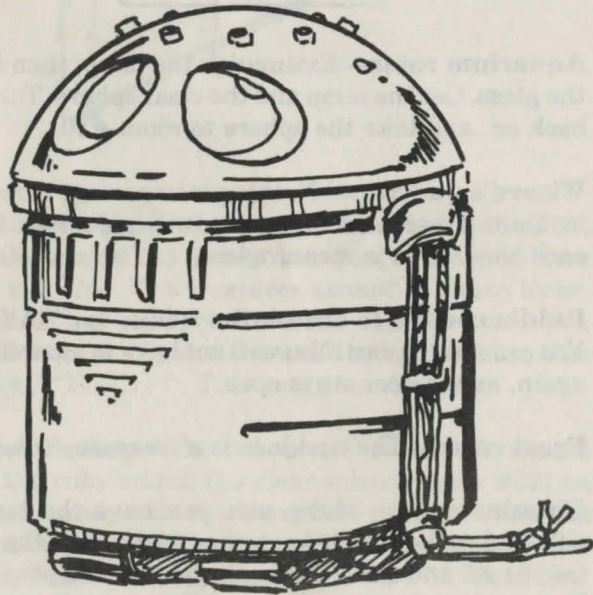

62. **Machine room**—Tell the robot to push the triangular button. Do not push the button yourself. Tell the robot to go south. Follow him and follow the instructions of room #63.
63. **Dingy closet**—Get the red sphere. When the cage comes down, tell the robot to lift the cage, and you get the sphere. Return to room #60, and follow the remaining directions.
64. **Menhir room**—To move the stone, you must get the wizard's wand (room #51, from the demon). Point the wand at the menhir, and say 'SAY "FLOAT"'.

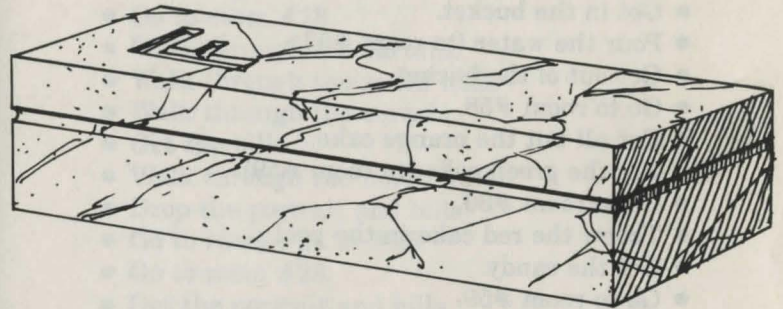

65. **Kennel**—The collar is needed in room #68.
66. **Stairway**—There is nothing important here.
67. **Oddly angled rooms**—Go west when you first get here. Then go:SE, NE, NW, SW, S, D. You will be in room #68.
68. **Cerberus room**—Put the collar from room #65 on the dog to go east.
69. **Crypt anteroom**—There is nothing important here.
70. **Crypt**—Spray the crypt with grue repellent. Turn the lamp off, look, open the door, turn on the lamp, and go south. Warning: if you fool around with the Flatheads' flat heads, you will die.

How to Win

- Get all.
- Go to room #8.
- Get the teapot.
- Go to room #5.
- Fill the teapot.
- Go to room #12.
- Go to room #54 (if you go somewhere else, check the map to get back to room #12, then try again).
- Say 'SAY "WELL."'
- Go to room #56.
- Get in the bucket.
- Pour the water (to room #57).
- Get out of the bucket.
- Go to room #58.
- Get all but the orange cake.
- Eat the green cake (to room #59).
- Go to room #60.
- Throw the red cake in the pool.
- Get the candy.
- Go to room #59.
- Eat the blue cake (to room #58).
- Go to room #61.
- Say "TELL ROBOT "GO EAST.PUSH TRIANG BUT-TON.GO SOUTH"'
- Go to room #63 (if you go to room #58, just try again).
- Get the sphere.
- Say "TELL ROBOT "LIFT CAGE"'
- Get the sphere.
- Go to room #57 (if you miss it, return to room #61 and try again).
- Get in the bucket.
- Fill the teapot (to room #56).
- Drop the teapot.
- Get out.
- Go to room #55.
- Get the necklace.
- Go to room #12.
- Open the box.

- Get the violin.
- Go to room #47.
- Give the candy to the head.
- Drop the sphere, violin, and necklace.
- Go to room #19.
- Say "KILL DRAGON."
- Go south (to room #71).
- Say "KILL DRAGON."
- Go south (to room #21).
- Say "KILL DRAGON WITH SWORD."
- Go west (to room #32).
- Go to room #29.
- Get the portrait.
- Go to room #28.
- Walk through the curtain.
- Walk through the south wall.
- Walk through the curtain.
- Get the bills.
- Walk through the north wall.
- Drop the portrait and bills.
- Go to room #24 or #25.
- Go to room #28.
- Get the portrait and bills.
- Walk through the curtain.
- Go south (to room #23).
- Go to room #20.
- Open the chest.
- If the princess leaves, follow her. Following her is more important than getting the statuette.
- If the chest didn't open the first time, open it again.
- Get the statuette (if you are still here).
- Follow the princess all the way to the gazebo (room #8).
- Wait until she leaves (on the unicorn).
- Drop the perfect rose (unless you are really a sentimentalist).
- Get the placemat and letter opener.
- Go to room #16.
- Open the lid.
- Slide the placemat under the door.
- Put the letter opener in the keyhole.

- Get the letter opener and placemat.
- Get the iron key.
- Unlock the door with the iron key.
- Open the door.
- Go to room #17.
- Get the sphere.
- Drop the key and letter opener.
- If you didn't get the statuette, go to room #20 and get it.
- Go to room #47.
- Unlock the door with the gold key.
- Get all.
- Go to room #50.
- Put the red sphere on the ruby stand.
- Put the blue sphere on the sapphire stand.
- Go to room #52.
- Extinguish the lamp (if it is on).
- Throw the lamp at the aquarium.
- Get the lamp and the clear sphere.
- Go to room #50.
- Put the clear sphere on the diamond stand.
- Get the black sphere.
- Go to room #51.
- Drop all but the lamp.
- Go to room #46.
- Get the string.
- Go to room #13.
- Get the brick.
- Go to room #8.
- Get the newspaper and matchbook.
- Go to room #35.
- Get the ruby.
- Go to room #36.
- Open the receptacle.
- Put the newspaper in the receptacle.
- Light a match.
- Light the newspaper with the match.
- Get in the balloon.
- Put the string in the brick.
- Wait until the balloon ascends to "Volcano near small ledge."

- Say "LAND" (to room #39).
- Tie the wire to the hook.
- Get out.
- Get the zorkmid.
- Go to room #40.
- Open the purple book.
- Get the stamp.
- Go to room #39.
- Get in the basket.
- Untie the wire.
- Wait until the balloon ascends to "Volcano near wide ledge."
- Say "LAND" (to room #43).
- Tie the wire to the hook.
- Go to room #44.
- Put the brick in the hole.
- Light a match.
- Light the string with the match.
- Go to room #43.
- Go to room #44.
- Get the crown.
- Go to room #43.
- Get in the basket.
- Untie the wire.
- Wait until you leave the ledge.
- Close the receptacle.
- Wait until you land.
- Get out of the basket.
- Go to room #51.
- Put the black sphere in the circle.
- Give all the treasures to the demon (necklace, gold key, statuette, bills, portrait, ruby, zorkmid, stamp, crown, and violin, excluding those that may have been filched from you).
- Say "DEMON, GIVE ME WAND."
- Go to room #64.
- Point the wand at the menhir.
- Say "SAY 'FLOAT.'"
- Go to room #65.
- Get the collar.
- Go to room #67.

- Go south (or some other direction until you find the club).
- Go SE, NE, NW, SW.
- Go the opposite direction you did to get here (or walk until you find the stairway leading down).
- Go to room #68.
- Put the collar on the dog.
- Go to room #70.
- Turn off the lamp.
- Look.
- Open the door.
- Light the lamp.
- Go south (make sure you didn't drop the wand).
- You have now won *Zork II*.

Zork II

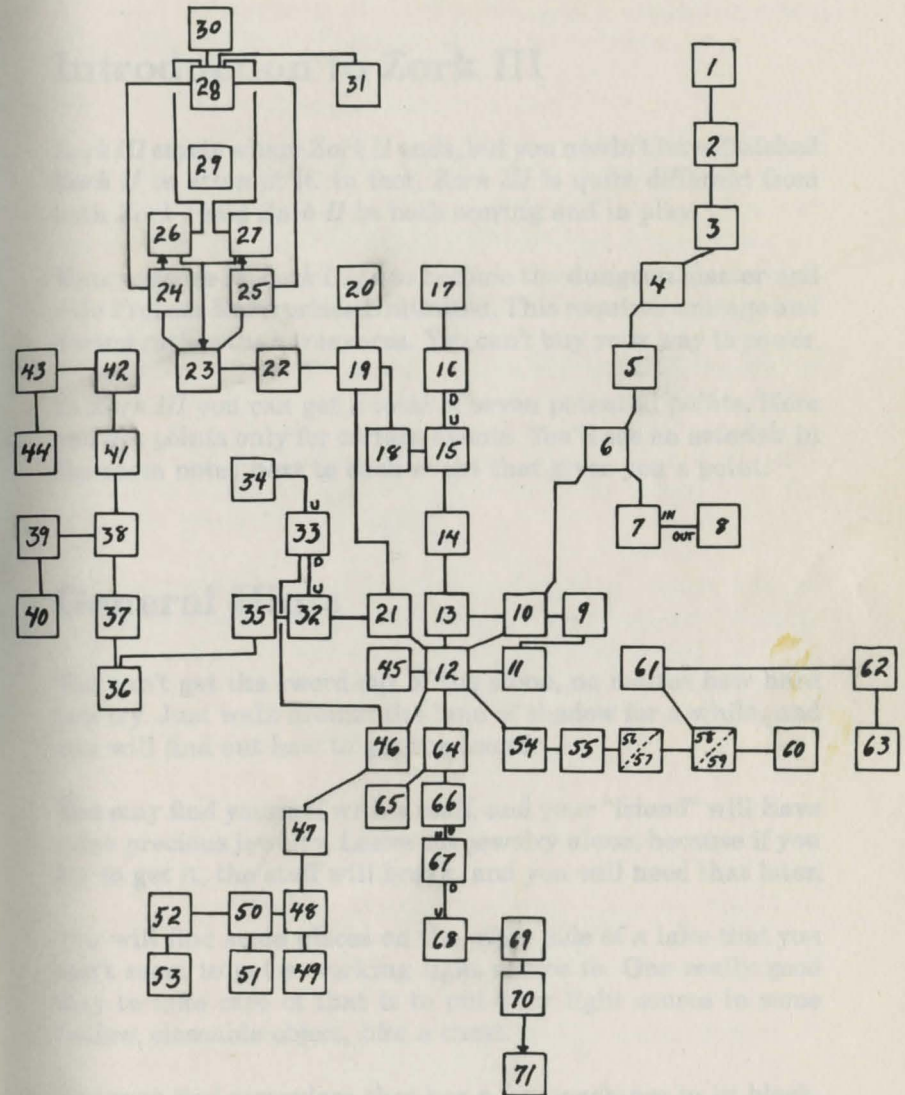

Zork III

Introduction to Zork III

Zork III starts where *Zork II* ends, but you needn't have finished *Zork II* to attempt it. In fact, *Zork III* is quite different from both *Zork I* and *Zork II* in both scoring and in play.

Your purpose in *Zork III* is to become the dungeon master and rule Frobozz Enterprises Unlimited. This requires courage and daring rather than treasures. You can't buy your way to power.

In *Zork III* you can get a total of seven potential points. Here you get points only for certain events. You'll see an asterisk in the room notes next to each event that gives you a point.

General Hints

You can't get the sword out of the stone, no matter how hard you try. Just walk around the land of shadow for a while, and you will find out how to get the sword.

You may find yourself with a staff, and your "friend" will have some precious jewelry. Leave the jewelry alone, because if you try to get it, the staff will break, and you will need that later.

You will find some places on the other side of a lake that you can't seem to get a working light source to. One really good way to take care of that is to put your light source in some hollow, closeable object, like a chest.

You may find someplace that has a few machines in it; black, grey, and gold. One of these works: the gold one. It is a time machine. It shows that you are in the year 948. If you read the

plaque in another room, you will see that some jewels were caged there in the year 777. In the year 776, the jewels were there, but the cage wasn't. The only really interesting treasure is a ring, and there is just enough room under the seat in the gold machine for a ring about that size to be hidden there.

Room Notes

1. **Endless stair**—Don't try to climb the stairs. This is where you will end up when you die. The lamp will always be here when you die. Take the lamp with you, since it is your only light source for right now.
2. **Junction**—The sword is in a rock here. You can't get it now. It will appear in your hand when you meet the figure.

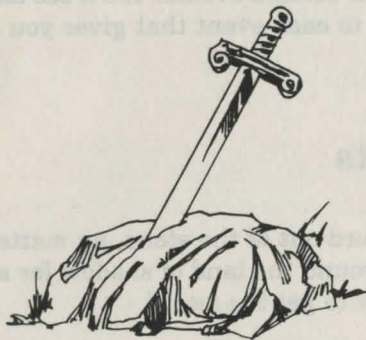

3. **Creepy crawl**—There is nothing to do here.
4. **Foggy room**—There is nothing to do here.
5. **Lake shore**—There is nothing to do here.
6. **Barren area**—There is nothing to do here.
7. **Damp passage**—You can get here from room #36.
8. **Dead end**—There is nothing to do here.

9. **Engravings room**—There is nothing to do here until you have the bread from room #13.

10. **Tight squeeze**—There is nothing to do here.

11. **Hairpin loop**—There is nothing to do here.

12. **Cliff base**—There is nothing to do here.

13. **Cliff**—There is a loaf of bread here. Wake the old man in room #9 and give it to him. He might not be there; if he isn't, just keep walking in until he is.

14. **Cliff edge**—There is a chest here. Get it and wait for a man to call down to you from room #13. He will ask you to tie the chest to the rope. Do it. Wait a while longer, and the man will ask you to grab the rope, which you should do. He will have opened the chest and gotten out the jewels. Don't try to get them from him. He will give you a staff. If you try to get the jewels, the staff will break. Keep the staff; you will need it later.

15. **Flathead ocean**—Come here and wait for a while. A sailor will come by in a ship. When you see him, say, "HELLO SAILOR." He will throw you a vial and leave. Keep the vial; you could need it later.

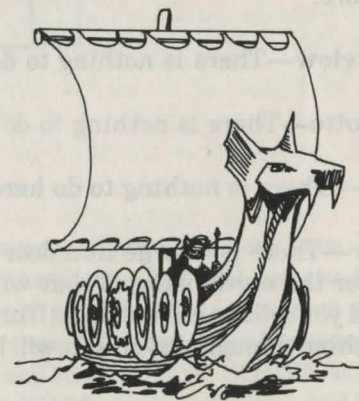



16. to 23. Land of shadow—Walk around in these rooms for a while until you see a hooded figure. *The sword will appear in your hand. *Start fighting the figure with it. When you get the message “He appears to be badly hurt and cannot defend himself,” get the hood. Then get the cloak. Keep them with you to use later. You may now drop the sword; you don’t need it anymore.

24. Aqueduct view—There is nothing to do here.

25. Crystal grotto—There is nothing to do here.

26. Royal hall—There is nothing to do here.

27. Great door—There is a large iron door here. You cannot open it. After the earthquake, a cleft will open up behind the door and you will be able to pass. *Warning:* do not push the gold machine through this door; it will become unusable.

28. Museum entrance—There is nothing to do here.

29. Technology museum—There are three machines here. The gold one is all you need worry about. You must push it into room #30.

30. Jewel room—Set the dial to 776. Then get in the machine and push the button. The machine and everything you were carrying will disappear. Get the ring. Wait a while until you hear the guards leave, then open the door, go west, open the wooden door, go north, and put the ring under the seat. Get in the machine, set the dial to 948, and push the button. Get out of the machine, look under the seat, open the door, go south, open the stone door, go east, and get all. You will now be where you started, and have everything you were originally carrying, plus the ring. Keep the ring, because you will need it later.

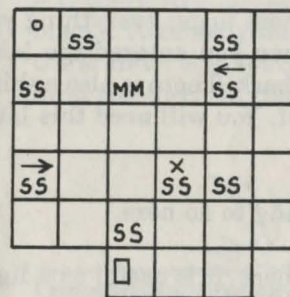

- x — book under block
- — hole in ceiling
- — ladder on east wall of block
- ← — ladder on west wall of block
- SS — sandstone block
- MM — marble block (moveable)
- — slot and door

31. Puzzle entrance—There is a note here. It is to warn you not to enter the puzzle lest you get stuck. Do not bother with the stupid note, but this is a good place to save the game, just in case. *Go down from here and follow the given instructions explicitly: “PUSH SOUTH WALL. SE. E. NE. N. PUSH EAST WALL. S W. S. PUSH SOUTH WALL. GET

BOOK. PUSH SOUTH WALL. N W. PUSH SOUTH WALL. E. E. N E. N. N. PUSH WEST WALL. N W. PUSH SOUTH WALL. E. SE. S. SW. NW. PUSHEAST WALL. W. NW. NW. NW. PUSH EAST WALL. PUSH EAST WALL. PUSH EAST WALL. S. PUSH SOUTH WALL. S W. SE. NE. PUSH WEST WALL. PUSH WEST WALL. S W PUSH NORTH WALL. PUSH NORTH WALL. PUSH NORTH WALL. N W. U.” If for any reason, you are unable to make any of these moves, then you have made a mistake. Restore the game that you should have saved in room #31. If you didn’t save it, re-start, and this time, follow the directions!

32. **Side room**—There is nothing to do here.
33. **On the lake**—When you enter the lake, you will drop anything you were carrying to room #34. If you have brought the lamp with you, make sure you put it in the chest and close the chest, or it will become unusable.
34. **Underwater**—You must come here to get everything you were carrying (not wearing) when you entered the lake. You will probably want to get it back. There is also a shiny object down here. It is an amulet. You will need this later also.
35. **Western shore**—There is nothing to do here.
36. **Scenic vista**—There is a torch here. It is useful as a light source if your lamp is running out. There are only two ways to get the torch out. It can be put in the chest and taken out through the lake. Or you can touch the table while it reads “II” and drop the torch in room #7 (or #2, #8, or #9). There is also a table here. It is used to transport yourself from this room to another, in one of the *Zorks*. To activate the table, *touch it. When the indicator reads I, it will send you a portion of *Zork I*: namely, the timber room. At II, it sends you to room 8 (in this book, it is room #66). When it points to III, it will send you to room #7 of this *Zork*; and when it reads IV, it sends you to room #67. This room is also in a newer adventure: *Enchanter*. Do not

go to room #67. You may read the description to see why. You will always reappear in room #36 after two turns, so do whatever you are going to do quickly.

37. **Southern shore**—There is nothing to do here.
38. **Dark place**—Please see description of room #40.
39. **Dark place**—Please see description of room #40.
40. **Key room**—There is a key here. You must keep it to use later. There are two ways to get to this room. You can either bring over a light source in the chest, or you can go to room #38 from the southern shore and spray yourself with the grue repellent from room 8 (#66 on the map). If you bring over the light source, you can leave the same way you came; but if you spray yourself with the grue repellent, you must leave via the aqueduct. If you do, you must do it before the earthquake. You will also find that when you get to room #7, there will not be a light source there (it will be pitch black). To remedy this situation, you can get the torch from the scenic vista, touch the table while the dial is at II, and drop the torch in room #7.

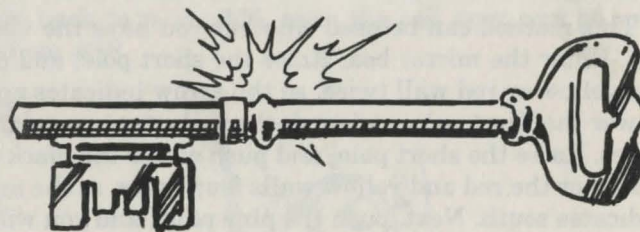

41. **Aqueduct**—There is nothing to do here.
42. **High arch**—You can only go north from here before the earthquake. If you do get here afterward, moving the arch will restart the game; otherwise you are forced to end the game (or you can wait around until your light runs out).

43. **Water slide**—This is a one way passage to room #7. It is also the only way out of here.
44. **Button room**—You must push the button here after following the instructions for room #45. This will open up the mirror box.
45. **Beam room**—There is a beam running along here. You must block this beam and push the button in room #44 to open the mirror box. You will not be able to block the beam and push the button at the same time by yourself, so block the beam with the chest.
46. **Hallway**—This hallway contains the mirror box to the north. There are two ways to get to room #51 (which is where you must get to). They are explained below:
1. To use this method, you must have the vial from the sailor at room #15. First, you must raise the short pole. Then, push the black or white wall twice, so the arrow indicates south. Then push the pine panel and go north. Now open the vial and drink the liquid. In case you don't know, it turns you invisible. Next, go north until you get to room #51.
 2. This method can be used whether you have the vial or not. Enter the mirror box. Raise the short pole, and push the yellow or red wall twice, so the arrow indicates north. Lower the short pole, and push the mahogany panel three times. Raise the short pole, and push either the black and white, or the red and yellow walls four times, so the arrow indicates south. Next, push the pine panel and you will be in room #51.
47. **Hallway**—Please see the description of room #46.
48. **Hallway**—Please see the description of room #46.
49. **Hallway**—Please see the description of room #46.
50. **Hallway**—Please see the description of room #46.

51. **Dungeon entrance**—When you get here, you should have either 6 or 7 points (touching the table gets you a point, but it isn't necessary). If, however, you do not have all the items, the Dungeon Master will send you back to the button room and you can try again. When you have all the items below, you can go to the engravings room and say "SAY FROTZ OZMOO," which happen to be two spells used in *Enchanter*, and you will appear before the door again. Knock on the door to get to room #52. You must be carrying the following: key, ring, hood, cloak, amulet, book, staff.
52. **Narrow corridor**—Tell the Dungeon Master to follow you, then go north to room #53.
53. **South corridor**—Either east or west will do, but you do need to get to room #56.
54. **East corridor**—There is nothing to do here.
55. **West corridor**—There is nothing to do here.
56. **North corridor**—Go north from here to room #57.
57. **Parapet**—Set the dial to 4, and push the button. Then, set the dial to 1, and tell the Dungeon Master to stay here, go back to room #56, open the cell door, and go south to room #58.

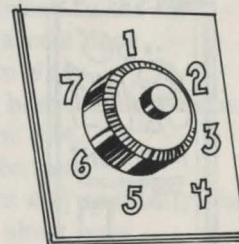

58. **Prison cell**—Tell the Dungeon Master to push the button. Then unlock the bronze door with the key from room #40, and open it. You can now go south to room #59.

59. **Treasury of Zork**—If you have gotten here, you really don't need to be reading this anymore. In other words, you have won *Zork III*!!!! (clap clap, scream for joy, jump up and down, kiss your dog).
60. **Timber room**—There is a piece of timber here. It is useless in this *Zork*, also. From here, there is a narrow passage leading east. So narrow, in fact, that you cannot carry anything through it (including a light source), so do not bother with it.
61. **Ladder bottom**—There is nothing to do here.
62. **Ladder top**—There is nothing to do here.
63. **Dead end**—You can't get the pile of coal here, because if you get here, you will return to the scenic vista immediately.
64. **Drafty room**—You can't see anything, so what's the use of coming here anyway?!?!
65. **Machine room**—There is nothing to do here.
66. **Room 8**—This is where you can find the can of grue repellent.



67. **Sacrificial altar**—There is a sacrificial altar here. If you come here, you will be sacrificially altered (you die).

How to Win

- Get the lamp.
- Go to room #13.
- Get the bread.
- Go to room #14.
- Get the chest.
- Wait.
- Tie the rope to the chest.
- Wait three times.
- Grab the rope.
- Get the chest.
- Walk around the Land Of Shadow (rooms #16-23) until you see the hooded figure.
- Kill the figure until he is badly hurt and can't defend himself.
- Get the hood.
- Drop the sword.
- Get the cloak.
- Go to room #9.
- Walk between #7 and #9 until the old man is in room #9 (unless he already is).
- Wake the man.
- Give the bread to the man.
- Open the secret door.
- Go to room #45.
- Block the beam with the chest.
- Go to room #44.
- Push the button.
- Go to room #47 (actually the mirror box).
- Raise the short pole.
- Push the yellow wall twice.
- Lower the short pole.
- Push the mahogany panel three times.
- Raise the short pole.
- Push the yellow wall four times.

- Push the pine panel.
- Knock on the door (to room #44).
- Go to room #35.
- Get the chest.
- Go to room #5.
- Turn off the lamp.
- Drop the lamp and staff.
- Enter the lake.
- Go to room #34.
- Get the chest and amulet (try till you get it).
- Go to room #36.
- Put the torch in the chest.
- Wait until the display reads something other than IV (if it doesn't already).
- Touch the table.
- Wait.
- Go to room #35.
- Close the chest.
- Enter the lake.
- Go to room #34.
- Get the chest (try till you get it).
- Go to room #37.
- Open the chest.
- Go to room #40.
- Put the key in the chest.
- Go to room #37.
- Close the chest.
- Enter the lake.
- Go to room #34.
- Get the chest (try till you get it).
- Go to room #5.
- Get the staff.
- Go to room #29.
- Push the gold machine south.
- Open the stone door.
- Push the machine east.
- Get in the machine.
- Set the dial to 776.
- Push the button.
- Get the ring.
- Wait for the guards to leave.

- Open the door.
- Go to room #28.
- Open the wooden door.
- Go to room #29.
- Put the ring under the seat.
- Get in the gold machine.
- Set the dial to 948.
- Push the button.
- Get out of the machine.
- Look under the seat.
- Open the door.
- Go to room #28.
- Get all.
- Go to room #31.
- Go down.
- Follow the quoted directions in room #31 of the instructions.
- Go to room #9.
- Say 'SAY "FROTZ OZMOO"' (don't forget the double quotes).
- Knock on the door.
- Say "DUNGEON MASTER, FOLLOW ME."
- Go to room #57.
- Set the dial to 4.
- Push the button.
- Set the dial to 1.
- Say "DUNGEON MASTER, STAY HERE."
- Go to room #56.
- Open the cell door.
- Go to room #58.
- Say "DUNGEON MASTER, PUSH BUTTON."
- Unlock the bronze door with the key.
- Open the bronze door.
- Go south.
- You have now won *Zork III*.

Enchanter

Introduction to Enchanter

Enchanter is another adventure game in the Zork tradition. If you played *Zork III*, you'll remember the sacrificial altar you could reach from the table. Since the altar is part of *Enchanter*, this game may be thought of as *Zork IV*.

In this game, you begin as an inexperienced enchanter who must defeat the warlock Krill to become a full-fledged member of the Circle of Enchanters. You begin with only four spells, which are explained in your spellbook:

- NITFOL** lets you converse with animals in their own tongues.
- GNUSTO** writes a new spell you find into your spell book.
- BLOB** encloses things in a magic box; it kills them if they're alive.
- FROTZ** causes a thing to give off light.

The authors find it handy to FROTZ the book at first, then later to FROTZ themselves! As you play the game, you'll have to get spells into your spellbook, learn them, and use them.

General Hints

As you play this game, you may get hungry and/or thirsty. There is a very simple way to take care of this. Get the bread from inside the oven and the jug (room #4) and fill it from the spring.

You will soon learn that in this game, you do not fight anyone with swords or knives, but you use spells for everything. There are quite a few spells to be found.

These spells must be GNUSTO'd into your spell book:

CLEESH	Turn a being into a small amphibian (on being).
EXEX	Make an object move with greater speed (on turtle).
GONDAR	Extinguish an open flame (on dragon).
KREBF	Repair willful damage (on ZIFMIA scroll).
MELBOR	Protect a magic user from evil (on self for stairs).
OZMOO	Survive unnatural death (on self for temple).
REZROV	Open locked or enchanted objects (on egg, west and north gates, and bedpost).
VAXUM	Make a hostile being friendly (on adventurer, being).
ZIFMIA	Summon a being (on adventurer, implementors).

These spells are too long to put in your spell book:

FILFRE	Create gratuitous fireworks (ad for Infocom).
GUNCHO	Banish a being to another plane of existence (on Krill).
IZYUK	Make a being fly (on self when on the stairs).
KULCAD	Dispel a magic spell (on the stairs).

In this game, you will also need a light source. You can use the FROTZ spell to turn anything into a light source. Do not FROTZ yourself, or you can't get the OZMOO spell. The authors of this book would suggest that you FROTZ the spell book to avoid carrying any extra items.

There is one important thing to remember; you must "LEARN" or "REMEMBER" every spell before you use it, not including the ones that don't go in your spell book.

Room Notes

1. **Fork**—Nothing is important here.
2. **Long road**—Do not come here unless you are very, very bored. If you read the sign, go west, read the sign, and so on, you will get the following message. "Why are you going

west when the castle is east? Burma Shave" Then the sign is too worn to read. You will have to go east the exact number of times you went west to return to room #1.

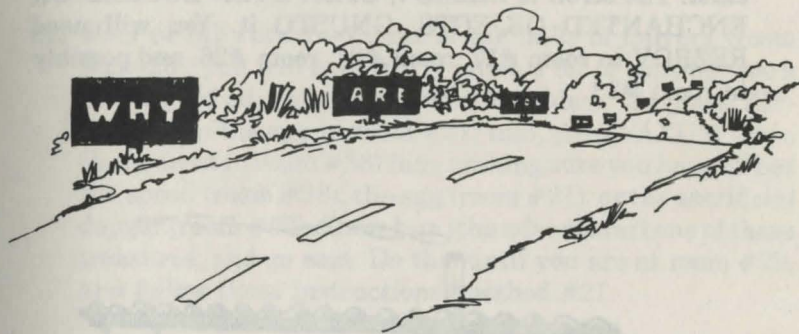

3. **Outside shack**—Nothing is important here.
4. **Inside shack**—Open the oven. Get the bread. Eat it when you get hungry. Get the jug. Go to room #7, and fill it. Drink the water when you are thirsty. Do not get the lamp. The "FROTZ" spell is a perfect light source. Do not FROTZ yourself yet. FROTZ the book. FROTZ is in your book at the start of the game, and you have learned it already.
5. **Trail**—Nothing is important here.
6. **Trail head**—Nothing is important here.
7. **Shady brook**—Fill the jug from room #4 here. When the jug is empty, come here to refill it. Do not drink the water from room #70 or room #28. They have unclean water.
8. **Eastern fork**—Nothing is important here.
9. **Village outskirts**—Nothing is important here.
10. **Deserted village**—Go south to get to room #13. You will not be able to stay there, so do not be surprised.
11. **Mountain trail**—Nothing is important here.

12. **Lonely mountain**—Nothing is important here.

13. **Hovel**—The crone will give you a scribbled scroll, and push you out the door. In other words, this room doesn't really exist. The scroll is REZROV, OPEN EVEN LOCKED OR ENCHANTED OBJECTS. GNUSTO it. You will need REZROV in room #17, room #21, room #26, and possibly in room #33.

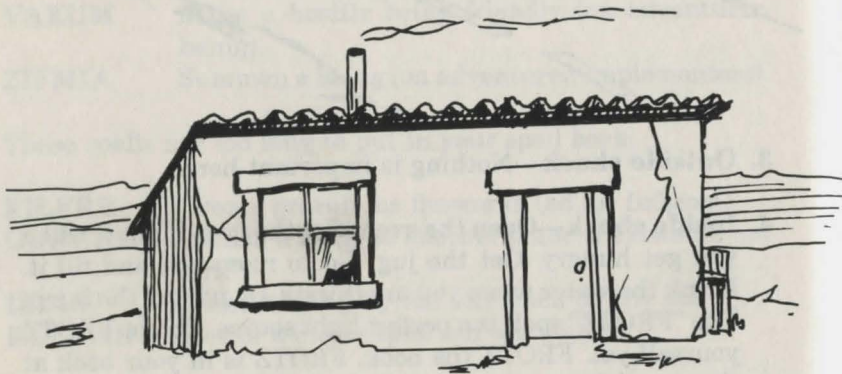

14. **Loop**—Nothing is important here.

15. **Dusty trail**—Nothing is important here.

16. **Western road**—Nothing is important here.

17. **Outside gate**—You must use the REZROV spell from room #13 to open the gate. Learn REZROV, then say "REZROV GATE."

18. **Inside gate**—Nothing is important here.

19. **Pebbled path**—Nothing is important here.

20. **Tower**—Nothing is important here.

21. **Jewel room**—The egg is reminiscent of the one in *Zork I*. However, there is no thief here to open it for you. Try the REZROV spell. The torn scroll can be reconstituted with KREBF, from room #27.

22. **Hall of Mirrors 1**—In one of the halls of mirrors (room #22–25), you will eventually (after a lot of waiting) see a bedraggled adventurer on the other side of the glass. ZIFMIA (from the egg in room #21) him, then VAXUM (from the bedpost in room #33) him, making sure you have either the spoon (room #38), the egg (room #21), or the sacrificial dagger (room #57). Show him (the adventurer) one of these treasures, and go east. Do this until you are at room #29, and follow those instructions (method #2).

23. **Hall of Mirrors 2**—See instructions for room #22.

24. **Hall of Mirrors 3**—See instructions for room #22.

25. **Hall of Mirrors 4**—See instructions for room #22.

26. **North gate**—Use REZROV (room #13) to open the gate. You should know how.

27. **Forest**—The crumpled scroll is KREBF: REPAIR WILLFUL DAMAGE. Use it on the scroll inside the egg from room #21, and you will get ZIFMIA: SUMMON A BEING. ZIFMIA can and should be used on the adventurer. He is found in one of rooms #22–25. Follow those instructions.

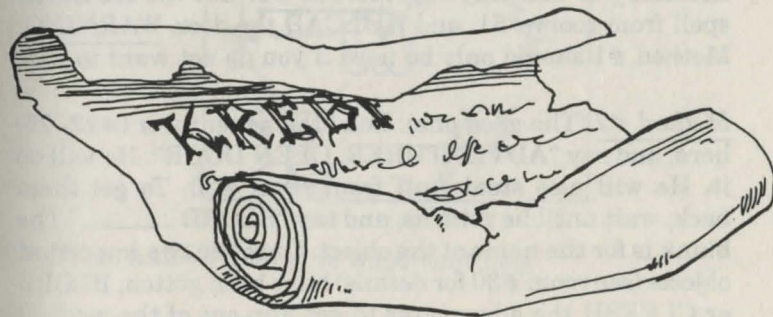



28. **Swamp**—There are many frogs here. There is a lot of water here. The water is undrinkable. So are the frogs. If you use NITFOL (it's in your book at the beginning, so you should already know what it is) on the frogs, you can understand what they are saying. Don't bother, I will tell you. They are saying "Breep! Look under the lily pad! Breep!" Look under the lily pad. The scroll is CLEESH:TURN A BEING INTO A SMALL AMPHIBIAN. It can be used on the being in room #68, the adventurer (rooms #22-25), or on yourself. Do not use it on yourself. It is not necessary for anything else.

29. **Guarded door**—There are two ways to open the door. The first way (method #1) is not suggested, because you can't win if you do that. Method #2 is a nice, safe way which is necessary to use. Anyway: Method #1: Get the KULCAD spell from room #51, and KULCAD the door. WARNING: Method #1 should only be used if you do not want to win.

Method #2 (The good one): Lead the adventurer (#22-25) here, and say "ADVENTURER, OPEN DOOR". He will do it. He will also steal stuff from room #30. To get them back, wait until he returns, and say "BLORB _____" The blank is for the name of the object. Once the two important objects (see room #30 for details) have been gotten, BLORB or CLEESH the adventurer to get him out of the way.

30. **Map room**—The map and pencil are very important. The purple scroll is FILFRE:CREATE GRATUITOUS FIREWORKS. You get no points for the FILFRE spell, but it is fun. It is also an ad for Dave Lebling, Marc Blank, Infocom, and *Enchanter*. Back to the map and paper. The map is a map of the translucent rooms. If you look at it, you will see the letter "P" standing all alone. That is why room #46 seems to have no passages connecting to it. It doesn't, yet. Read the runes on the pencil. The Frobozz Magic Pencil Company is a subsidiary of FrobozzCo, which makes huge boats, great robots, and adventures. Their pencils can create passages if the passages are drawn on a map. They can also erase. However, since FrobozzCo is new at the pencil game, they make very short-lived pencils. Each end of the pencil (point and eraser) can only be used twice. On with the uses. If you have read the book in room #61, you probably have read of the Unseen Terror. If you haven't, tough! The Unseen Terror is trapped in room #46. There is a very good scroll there. To get it, but not the Terror, draw a line between F and P. Wait. Erase the line between B and R. Erase the line between M and V. Draw a line between B and K or J. You can now go down there and get the scroll. Read the instructions down there.

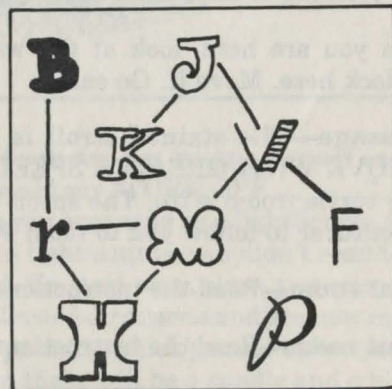

31. **West hall**—Nothing is important here.

32. **Tower**—Nothing is important here.

33. **Bedroom**—This is where you should sleep. There is a scroll in the bedpost. If you are getting the scroll before your first sleep, use REZROV (room #13) on the bedpost; otherwise, look at the bedpost and push the button. (That's what the dream meant.)

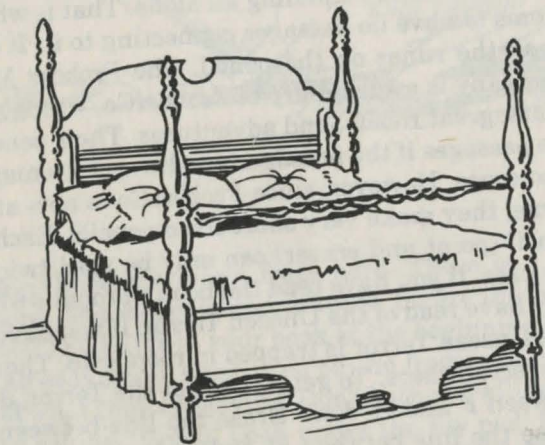

34. **South Hall**—Nothing is important here.
35. **Dungeon**—Nothing is important here.
36. **Cell**—When you are here, look at the wall. There is a moveable block here. Move it. Go east.
37. **Secret passage**—The stained scroll is EXEX:MAKE THINGS MOVE WITH GREATER SPEED. It should be used on the turtle (room #70). The spoon can be used to get the adventurer to follow you to room #29.
38. **Translucent room**—Read the instructions for room #30.
39. **Translucent room**—Read the instructions for room #30.
40. **Translucent room**—Read the instructions for room #30.
41. **Translucent room**—Read the instructions for room #30.
42. **Translucent room**—Read the instructions for room #30.

43. **Translucent room**—Read the instructions for room #30.
44. **Translucent room**—Read the instructions for room #30.
45. **Translucent room**—Read the instructions for room #30.
46. **Translucent room**—There is a scroll emanating power here. It is GUNCHO: BANISH A BEING TO ANOTHER PLANE OF EXISTENCE. It cannot be written in your spell book. It should be used on Krill. Go to room #65 and follow those directions, once you have gotten GONDAR (room #61), CLEESH (room #28) or VAXUM (room #33), KULCAD (room #51), and MELBOR (room #52).

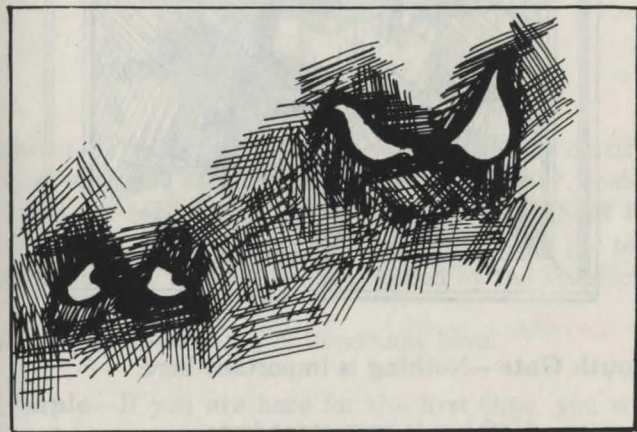

47. **Gallery**—If you are not using yourself as a light source, then you should say "TURN OFF _____". The blanks are for the item you are using as a light source. If you are using yourself as a light source, you didn't read the instructions for room #4. So start over, since you cannot win. If, however, you followed directions and are now in the dark, look. The lighted painting which you see before you can be moved. Move it, and there will be a candle and a black scroll. This scroll is OZMOO: PROTECT A BEING FROM UNNATURAL DEATH. If you cannot see the use in that, you are hopeless. By the way, if you have played *Zork III*, you will remember the words "FROTZ OZMOO". Think about it.

Anyway, OZMOO should be used in room #55, it will also come into play in room #57. What you should do is this: learn OZMOO, go to room #54 after dropping all scrolls, like KULCAD (room #51) and GUNCHO (room #46). When you are thrown into the cell, OZMOO yourself. Wait until the figure tries to kill you. Now follow the directions.



48. **South Gate**—Nothing is important here.
49. **Tower**—Nothing is important here.
50. **Engine room**—There is a scroll in the room to the southeast. To get it, you will need the turtle from room #70. Learn the spells NITFOL and EXEX. NITFOL the turtle. Tell him to follow you. Come up here and EXEX him. Wait until the hammer hits the ground. Right after that, say "TURTLE, GO SE, GET SCROLL, GO NW". Get the scroll, which is KULCAD:DISPEL A MAGIC SPELL. Use it at room #65.
51. **Control room**—If you have gotten here, you cannot get out. Even OZMOO will not save you. You must now restart the game.

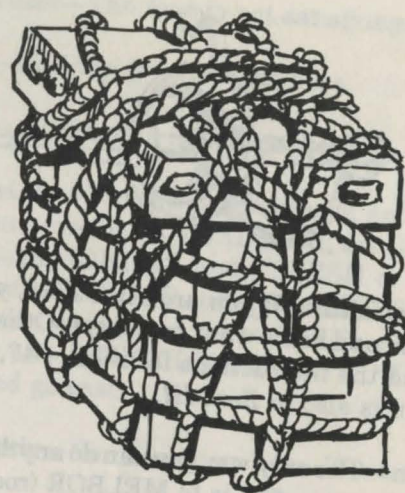

52. **Closet**—The box here can only be opened by cutting the ropes with the sacrificial knife from room #57. Inside the box is the MELBOR:PROTECT A MAGIC USER FROM EVIL spell. Use it on yourself so that you can get to room #58 and past without being grabbed by the fanatics.
53. **Courtyard**—Nothing is important here.
54. **Temple**—If you are here for the first time, you will get thrown into room #55, and then to room #57. In room 57 you will probably be sacrificially altered, unless you have gotten OZMOO from room #47. Follow those directions.
55. **Cell**—If you do not know OZMOO, you can write this game off. If you do, OZMOO yourself, and when they try to stab you, you will get the knife. Use it in room #52, and possibly on the adventurer, to lead him to room #29. Your possessions are kept in room #56.
56. **Cell**—Your possessions, except the KULCAD and GUNCHO scrolls, are stored here when you get thrown into room #55. These two scrolls are lost forever if you let the chanters get their bloodthirsty little hands on them.

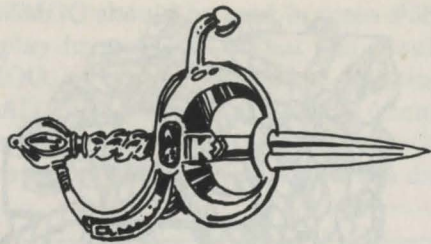

57. **Sacrificial altar**—If you are alive here, you have gotten the dagger, and know what to do here. Otherwise, you have died. Read the instructions for room #47, if you die here. This room is also in *Zork III*.
58. **Junction**—The only way you can do anything here besides be taken to room #55 is to MELBOR (room #52) yourself before coming here. You can now go east.
59. **Courtyard**—Nothing is important here.
60. **Courtyard**—Nothing is important here.
61. **Library**—The dusty book tells of the Great Implementors. You can ZIFMIA (room #21, inside the egg) them. There is no importance to this. You can also read about the Unseen Terror. He is in room #46. Read the description in room #30 for more explanation. If you look at the rat tracks, you will see a hole. Reach in the hole, and get a scroll. It is GONDAR:EXTINGUISH AN OPEN FLAME. Use it on the dragon in room #68. If the hunched shapes come in here, and come at you, either MELBOR yourself, or VAXUM them.



62. **Banquet hall**—The food is not satisfying.
63. **Kitchen**—Nothing is important here.
64. **East hall**—Nothing is important here.
65. **Winding stair**—You can go up forever, and down forever. Don't. If you have the KULCAD scroll, the GUNCHO scroll, and can learn GONDAR and CLEESH or VAXUM, you can win. Learn GONDAR and either CLEESH or VAXUM. KULCAD the stairs, and you will be in a bottomless pit with a new scroll, IZYUK:MAKE A THING FLY. IZYUK yourself, and go east.
66. **Winding stair**—Don't come up here. It is a waste of time.
67. **Winding stair**—Don't come down here. It is a waste of time.
68. **Krill's workshop**—GONDAR the dragon when he appears, CLEESH or VAXUM the being when it appears, and while Krill is preparing to destroy you, GUNCHO him. You have now won *Enchanter*.



- 69. Meadow**—Nothing is important here.
- 70. Beach**—Learn NITFOL; NITFOL the turtle, tell him to follow you, go to room #50, and follow those directions.
- 71. Courtyard**—Nothing is important here.
- 72. Courtyard**—Nothing is important here.
- 73. Courtyard**—Nothing is important here.

How to Win

- FROTZ the book.
- Go to room #4.
- Open the oven.
- Get the jug and bread.
- Go to room #7.
- Drink the water.
- Fill the jug.
- Go to room #10.
- Go south (back to room #10 with REZROV).
- GNUSTO REZROV.
- Learn REZROV twice.
- Go to room #17.
- REZROV the gate.
- Go to room #21.
- REZROV the egg.
- Get the scroll.
- Go to room #26.
- Learn REZROV.
- REZROV the gate.
- Go to room #27.
- Get the scroll.
- GNUSTO KREBF
- Learn KREBF, REZROV.
- KREBF the scroll.
- GNUSTO ZIFMIA
- Go to room #61.
- Look at the tracks.

- Reach in the hole.
- GNUSTO GONDAR.
- Go to room #36 (the long way around).
- Open the cell door.
- Go to room #35.
- Move the block.
- Go to room #37.
- Get the scroll.
- GNUSTO EXEX.
- Go to room #34.
- Turn off the book.
- Go to room #47.
- Move the lighted painting.
- Get the scroll.
- GNUSTO OZMOO
- Turn on the book.
- Go to room #70.
- Learn NITFOL.
- NITFOL the turtle.
- Say "TURTLE, FOLLOW ME."
- Go to room #50.
- Learn EXEX.
- EXEX the turtle.
- Say "TURTLE, GO SE, GET SCROLL, GO NW."
- Thank the turtle (just to be nice).
- Get the scroll.
- Go to room #33.
- REZROV the bedpost.
- Get the scroll.
- GNUSTO VAXUM.
- Get on the bed.
- Get up.
- Go to room #21.
- Get the egg.
- Learn ZIFMIA, VAXUM.
- Go to one of the halls of mirrors (#22-#25).
- Wait until the adventurer stops and stares in your direction.
- ZIFMIA the adventurer.
- VAXUM the adventurer.
- Show the egg to the adventurer.

- Go to room #29.
- Say "ADVENTURER, OPEN THE DOOR."
- Go to room #30.
- Get the pencil.
- Give the egg to the adventurer.
- Get the map.
- Draw a line from F to P.
- Wait.
- Erase the line from B to R.
- Erase the line from M to V.
- Draw a line from B to J.
- Learn OZMOO,BLORB.
- BLORB the brittle scroll.
- Go to room #58.
- If the beings haven't gotten you yet, go east (you are now in room #55).
- OZMOO self.
- Wait until the beings come get you (to room #57).
- Go to room #54.
- Open the south cell door.
- Go to room #56.
- Get all but the map and pencil.
- Go to room #52.
- Cut the rope with the knife.
- Open the box.
- Get the scroll.
- GNUSTO MELBOR.
- Go to room #46 (according to the map you have drawn).
- Get the scroll.
- Go to room #33.
- Get on the bed.
- Get up.
- Go to room #26 (via halls of mirrors).
- Open the box.
- Get the scroll.
- Learn MELBOR, GONDAR, VAXUM.
- MELBOR self.
- Go to room #65.
- KULCAD the stairs.
- IZYUK self.

- Go east (to room #68).
- GONDAR the dragon.
- VAXUM the being.
- GUNCHO Krill.
- You have now won *Enchanter*.

Enchanter

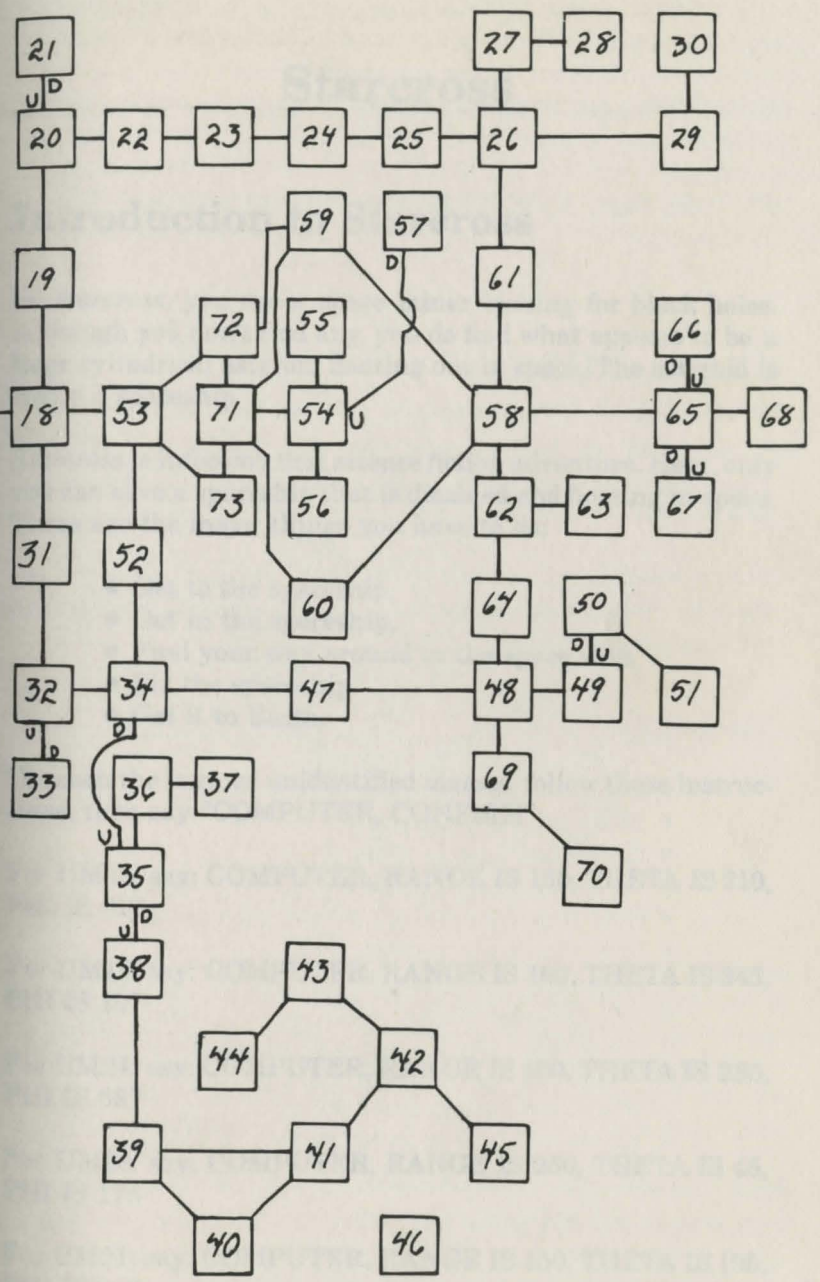
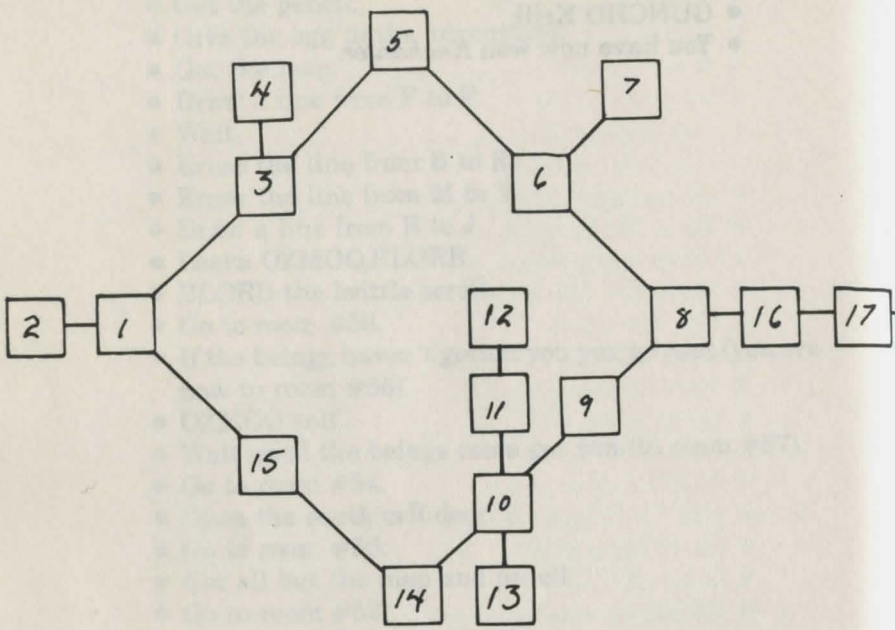

Starcross

Introduction to Starcross

In *Starcross*, you are a space miner looking for black holes. Although you don't find any, you do find what appears to be a huge cylindrical asteroid floating out in space. The asteroid is really a spaceship.

Starcross is Infocom's first science fiction adventure. Here, only you can save a spaceship that is disabled and floating in space. These are the major things you have to do:

- Get to the spaceship.
- Get in the spaceship.
- Find your way around in the space ship.
- Fix the spaceship.
- Get it to Earth.

To reach the various unidentified masses, follow these instructions, then say "COMPUTER, CONFIRM":

For UM08: say: COMPUTER, RANGE IS 150, THETA IS 210, PHI IS 017

For UM12: say: COMPUTER, RANGE IS 100, THETA IS 345, PHI IS 107

For UM24: say: COMPUTER, RANGE IS 100, THETA IS 285, PHI IS 087

For UM28: say: COMPUTER, RANGE IS 250, THETA IS 45, PHI IS 178

For UM31: say: COMPUTER, RANGE IS 150, THETA IS 105, PHI IS 067

For UM52: say: COMPUTER, RANGE IS 175, THETA IS 165,
PHI IS 035

For UM70: say: COMPUTER, RANGE IS 100, THETA IS 135,
PHI IS 101

For UM91: say: COMPUTER, RANGE IS 50, THETA IS 15,
PHI IS 121

General Hints

In *Starcross*, as in the *Zorks*, you will need to see. The only place that you cannot see at the beginning of the game is the yellow hall. To make this hall light, use the yellow rod.

This game has a number of rods and a number of slots to put them in. The rods should be put in the corresponding slot (violet rod in violet slot, etc.).

The rods are:

- Black rod (can be used in room #43).
- Blue rod (use in room #77).
- Brown rod (use in room #77).
- Clear rod (use in room #77).
- Gold rod (use in room #76 to get into room #77).
- Green rod (use in room #77).
- Pink rod (use in room #77).
- Red rod (use in room #58, in the second slot).
- Silver rod (use in room #69 to get into room #70).
- Violet rod (use in room #77).
- White rod (use in room #70).
- Yellow rod (use in room #58).

At one point in the game, you will have to find the mechanical mouse. This metal rodent moves around a lot, so it may be hard to find him. If you just stay in one place, you will find it.

At another point in the game, you will have to go to the alien chieftain in room #13. Do not go there unless you have gotten and used the transportation disks in room #39, fixed the air in room #58 and gotten the pink rod in room #35. If, by accident, you go to room #13, and the chief sees you before you have done all of these things, the game will then become unsolvable, and you must either RESTORE a saved game, RESTART the game, or QUIT.

Room Notes

1. **Living quarters**—Get the tape library. You will need it in room #49.

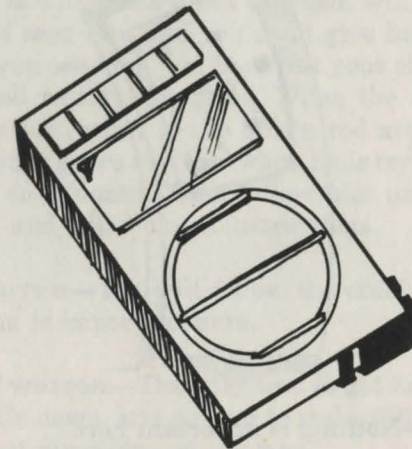

2. **Bridge**—To stop the mass detector from ringing, push the red button. Before going to the unidentified mass, get in the couch, and fasten the belt. Stay there until the ropes from the cylindrical ship grab your ship. To go to the appropriate mass, follow the directions given in the introduction.
3. **Storage**—Get the suit and the line. Wear the suit until the alien chieftain in room #13 wants it. Before you give him the suit, be sure that you have the pink rod from room #35, and that you have fixed the air at room #58.

4. **Airlock**—Do not come out here unless you are wearing the space suit and have gone to the cylindrical ship. Close the inner door before opening the outer door, or you will die.

5. **Red dock**—The bumps on the door are a representation of the solar system (the Sun, Mercury, Venus, Earth, Mars, Jupiter, Saturn, Uranus, Neptune, and Pluto). Push the fourth bump (Earth), and a tiny bump will appear. Push it. Now take the black rod. It can be used in room #43. The door has been opened, and you can go into the main setting of *Starcross*! Aren't you proud?

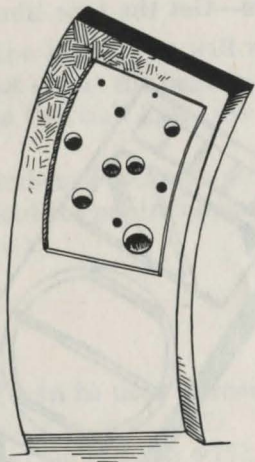

6. **Red hall**—Nothing is important here.

7. **Red hall**—Nothing is important here.

8. **Red hall**—Nothing is important here.

9. **Red hall**—Nothing is important here.

10. **Red hall**—Nothing is important here.

11. **Outskirts of village**—Nothing is important here.

12. **Outskirts of village**—Nothing is important here.

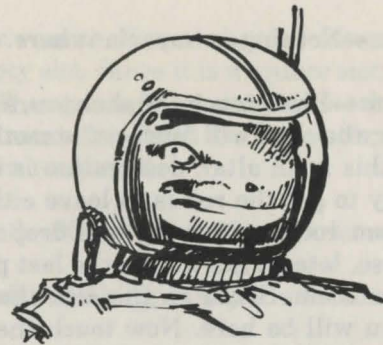

13. **Village center**—Do not come here unless you have found and used the red and blue transportation disks (room #39), fixed the air in room #58, and gotten the pink rod at room #35. This is where the alien chieftain will first find you. If the chief sees you, and you don't give him the suit the first time you see him, you have lost your chance, and you may as well restart the game. When the chief points to your space suit, point to the brown rod around his neck. Give him your space suit and when he is trying to hide the rod, point to it again. Then follow him until you are at room #15, and follow those instructions.

14. **In the warren**—You will follow the chief through here, but nothing is important here.

15. **Center of warren**—The only way to get here is to follow the chief. Go down, and go over to room #21, following the intermittent directions on the way.

16. **Green airlock**—Close the inner door before opening the outer door, and vice-versa.

17. **Green dock**—Nothing is important here.

18. **Umbilical**—Nothing is important here.

19. **Cargo hold**—The visor fragment may be used in room #43, but so can the black rod, so there is nothing here that cannot be replaced.

20. **Guard room**—Nothing is important here.

21. **Control room**—If you touch the skeleton, a violet rod falls out. However, the chief will “suspect” something, and rush here. Since this is an altar, desecration is not suggested. The only way to get the rod is to leave either the red or blue disk from room #39 here, and drop the other one someplace else, later. This will be the last place you get a chance to use them. Stand on the disk that is outside of here, and you will be here. Now touch the skeleton, get the disk, drop the disk, and stand on it. The perfect crime.

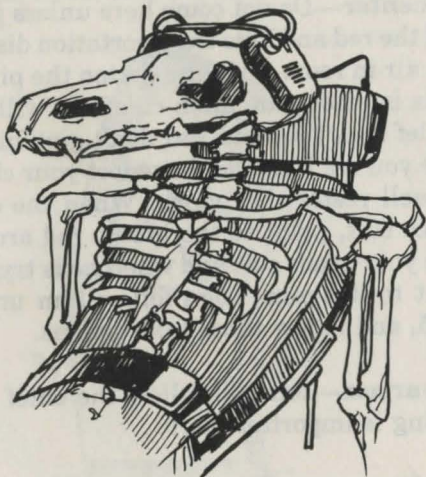

22. **Green hall**—Nothing is important here.

23. **Green hall**—Nothing is important here.

24. **Outskirts of village**—Nothing is important here.

25. **Village suburbs**—Nothing is important here.

26. **Outskirts of village**—Nothing is important here.

27. **Green hall**—Nothing is important here.

28. **Room on ring one**—Nothing is important here.

29. **Computer room**—If you open the access panel, you will see an empty slot. Since it is a square slot, a square should go into it. The square from room #58 works very well. Once you have inserted it, turn the computer on. The gold rod is needed in room #76.

30. **Yellow hall**—Nothing is important here.

31. **Yellow hall**—Nothing is important here.

32. **Yellow hall**—Nothing is important here.

33. **Yellow airlock**—Be sure that you are wearing your space suit before you go outside. The basket here is a good thing to put rods in. Get it before you open the outer door, or it will float away. You will have to open the outer door twice before it opens. As always, close the inner door first. Before you go out, be sure that the safety line is tied to your space suit.

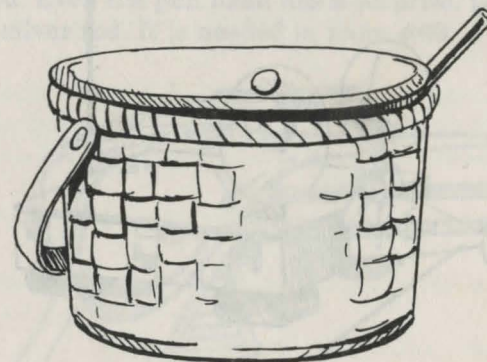

34. **Yellow dock**—Tie the line to the hook or you will float away.

35. **Among debris**—Get the rod and put it in the basket that you should have gotten (room #33). Now go back inside.

36. **Yellow hall**—Nothing is important here.

37. **Outskirts of village**—Nothing is important here.

38. **Yellow hall**—Nothing is important here.
39. **Laboratory**—These disks are transporter disks. If you drop one in one place, and the other somewhere else, and stand on one of them, you will be transported to the other. Inside the globe is a blue rod. To get it, put one disk under the sphere, drop the other one, put something (anything but a disk) on the sphere, and set the dial to 4. Poof! Set the dial to 1, 2, or 3, and get both disks, the rod, and the thing you put on the sphere, if it is useful somewhere else. The disks have two other uses: first, if you can find the mechanical mouse, drop one of the disks, and he (she? it?) will pick it up. Follow the mouse until it goes into its hole, and wait until it leaves. Now go to a spot that you can easily find again, and drop the remaining disk. Stand on the disk, and you will be transported to room #55. Follow the instructions there for the rest of this use. Second, the disks have a use in room #21, which is detailed there.

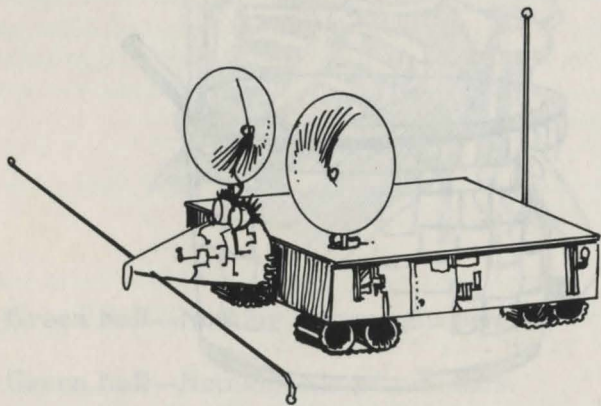

40. **Yellow hall**—Nothing is important here.
41. **Blue hall**—Nothing is important here.
42. **Blue hall**—Nothing is important here.
43. **Observatory**—Look at the projector through either the visor fragment from room #19, or the black rod from room #5, and get the clear rod.

44. **Blue hall**—Nothing is important here.
45. **Blue hall**—Nothing is important here.
46. **Blue airlock**—Close the inner door before you open the outer.
47. **Blue dock**—Nothing is important here.
48. **Bubbles**—Nothing is important here.
49. **Spherical ship**—Give the tape library to Gurthark (the spider), and he will give you a yellow rod. Get the rod, you will need it in room #58.
50. **Melted spot**—Nothing is important here.
51. **Weapons deck**—The ray gun is needed to get from room #71 to room #75. It is also needed in room #82, to get the red rod. Even the gun itself has a surprise. Look in it, and get a silver rod. It is needed in room #69.

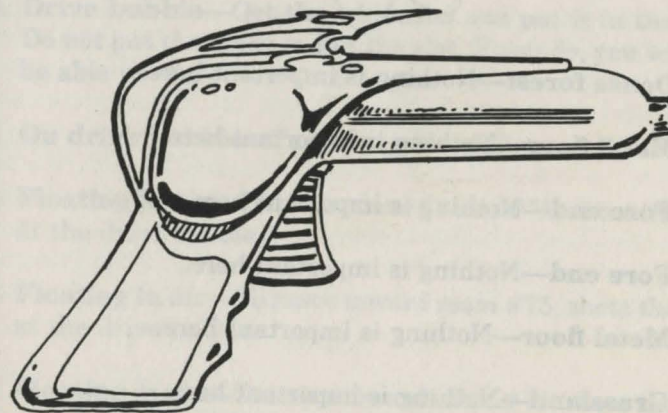

52. **Blue hall**—Nothing is important here.
53. **Room on ring four**—Nothing is important here.
54. **Blue hall**—Nothing is important here.

55. **Garage**—When you have arrived here, get the disk, and empty the bin. Empty the bin until you get a green rod. This rod is used in room #77.

56. **Grassland**—Nothing is important here.

57. **Thin forest**—Nothing is important here.

58. **Repair room**—The square is needed in room #29. Put the yellow rod from room #49 in the yellow slot to get light in the yellow hall. Put the red rod from room #82 in the second red slot (the diagram is an oxygen atom).

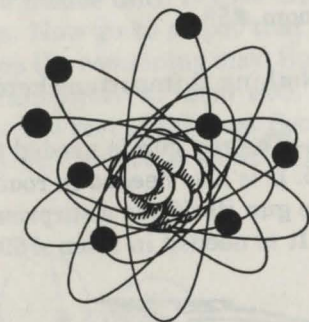

59. **Dense forest**—Nothing is important here.

60. **Metal floor**—Nothing is important here.

61. **Fore end**—Nothing is important here.

62. **Fore end**—Nothing is important here.

63. **Metal floor**—Nothing is important here.

64. **Grassland**—Nothing is important here.

65. **Thin forest**—Nothing is important here.

66. **Base of tree**—You can only climb the tree if you are not carrying the space suit. The best place to get rid of it is at room #13.



67. **Up a tree**—Nothing is important here.

68. **Top of tree**—To get to room #69, say “JUMP.”

69. **Drive bubble entrance**—Put the silver rod (from the ray gun in room #51) in the slot.

70. **Drive bubble**—Get the white rod and put it in the slot. Do not put the black rod in the slot. If you do, you will not be able to win.

71. **On drive bubble**—To get to room #72, say “JUMP.”

72. **Floating in air**—To move toward room #75, shoot the gun at the drive bubble.

73. **Floating in air**—To move toward room #75, shoot the gun at the drive bubble.

74. **Floating in air**—To move toward room #75, shoot the gun at the drive bubble.

75. **On control bubble**—Nothing is important here.

76. **Control bubble entrance**—To get in, put the gold rod (from room #29) in the slot.

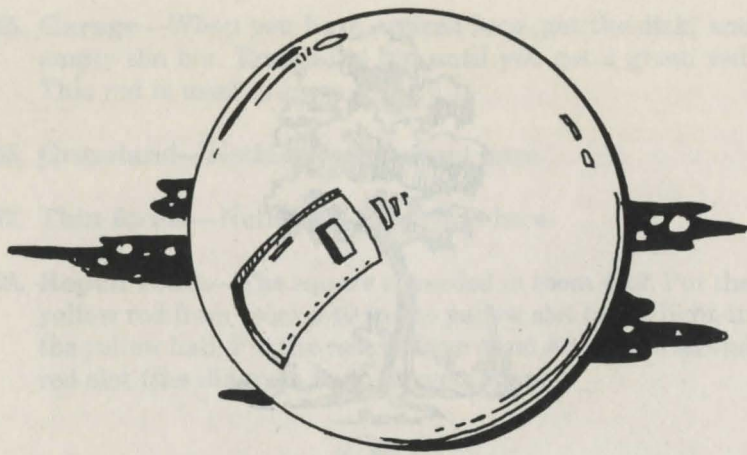

77. Control bubble—Put the clear rod in the slot. Five slots will appear. Put the brown rod (from the alien chieftain [room #13]) in the brown slot, the violet rod (from room #21) in the violet slot, the green rod (from room #55) in the green slot, the pink rod (from room #35) in the pink slot, and the blue rod (from room #39) in the blue slot. Push the following buttons in this exact order. Push the large pink square, to set the course toward the inner solar system. Push the brown spot to choose your destination. Since Earth is your home, that would be a good destination, so push the brown spot four-times. The violet spot chooses how you want to come in. You don't want to go straight there, or you will crash. Looping around Earth will make you end up out in space. Push the violet spot three or four times. The green button chooses speed. Going too slow would be boring. Going too fast would not be fun. Push the green button twice. Push the blue button to launch. You have now won *Starcross*.

78. Room on ring two—Nothing is important here.

79. Zoo—Nothing is important here.

80. Broken cage—Nothing is important here.

81. Inside grue cage—Nothing is important here.

82. Nesting cage—There is a red rod in the cage. It is needed in room #58. To get it, you must get the rat-ants away from the nest. Since the nest is "precariously balanced," throwing something heavy at it will knock it down, and move the rat-ants. The gun from room #51 is very heavy. Throw the gun at the nest, and get it and the rod back.



83. Red airlock—Nothing is important here.

84. Outskirts of village—Nothing is important here.

How to Win

- Get up.
- Get the tape library.
- Go to room #3.
- Get the suit and line.
- Wear the suit.
- Tie the line to the suit.
- Go to room #2.
- Look at the screen.
- Follow the directions in the introduction to *Starcross* to get to the mass.
- Sit on the couch.
- Fasten the belt.

- Unfasten the seatbelt.
- Get up.
- Open the bulkhead.
- Go to room #4.
- Close the inner door.
- Open the outer door.
- Go to room #5.
- Push the fourth bump.
- Push the tiny bump.
- Get the black rod.
- Go to room #83.
- Close the outer door.
- Open the inner door.
- Go to room #51.
- Get the gun.
- Look in the gun.
- Get the silver rod.
- Go to room #82.
- Throw the gun at the nest.
- Get the gun, red rod.
- Go to room #45.
- Open the inner door.
- Go to room #46.
- Close the inner door.
- Open the outer door.
- Go to room #49.
- Give the tape library to the spider.
- Get the yellow rod.
- Go to room #46.
- Close the outer door.
- Open the inner door.
- Go to room #57.
- Open the hatch.
- Go to room #58.
- Put the red rod in the second red slot.
- Put the yellow rod in the yellow slot.
- Get the square.
- Go to room #43.
- Look at the projector through the black rod.
- Get the clear rod.
- Drop the black rod.

- Go to room #29.
- Open the access panel.
- Put the square in the slot.
- Turn the computer on.
- Get the gold rod.
- Go to room #32.
- Open the inner door.
- Go to room #33.
- Get the basket.
- Put all the rods in the basket.
- Close the inner door.
- Open the outer door.
- Open the outer door.
- Go to room #34.
- Tie the line to the hook.
- Go to room #35.
- Get the pink rod.
- Put the pink rod in the basket.
- Go to room #34.
- Untie the line.
- Go to room #33.
- Close outer door.
- Open inner door.
- Untie the line.
- Go to room #39.
- Get the red disk, blue disk.
- Put the red disk under the globe.
- Drop the blue disk.
- Put the safety line on the globe.
- Turn the dial to 4.
- Get the blue disk, blue rod, safety line.
- Drop the safety line.
- Turn the dial to 1.
- Get the red disk.
- Go to room #38.
- Wait until the mechanical mouse enters the room.
- Drop the red disk.
- Follow the mechanical mouse until it enters its hole.
- Go to room #53.
- Drop the blue disk.
- Stand on the blue disk.

- Get the red disk.
- Empty the bin until you can see the green rod.
- Get the green rod.
- Put the green rod in the basket.
- Go to room #53.
- Get the blue disk.
- Drop the blue disk.
- Go to room #13.
- Take off the suit.
- Point to the brown rod.
- Give the suit to the chieftain.
- Point to the brown rod.
- Follow the chieftain until you are at room #15.
- Go to room #16.
- Close the inner door.
- Open the outer door.
- Go to room #21.
- Touch the skeleton.
- Get the violet rod.
- Put the violet rod in the basket.
- Drop the red disk.
- Stand on the red disk.
- Go to room #68.
- Jump.
- Put the silver rod in the silver slot.
- Go to room #70.
- Get the white rod.
- Put the white rod in the white slot.
- Go to room #71.
- Jump.
- Shoot the gun at the drive bubble three times.
- Go to room #76.
- Put the gold rod in the gold slot.
- Go to room #77.
- Put the clear rod in the clear slot.
- Put the brown rod in the brown slot.
- Put the violet rod in the violet slot.
- Put the green rod in the green slot.
- Put the pink rod in the pink slot.
- Put the blue rod in the blue slot.
- Push the large pink square.

- Push the brown spot four times.
- Push the violet spot three times.
- Push the green spot twice.
- Push the blue button.
- You have now won *Starcross*.

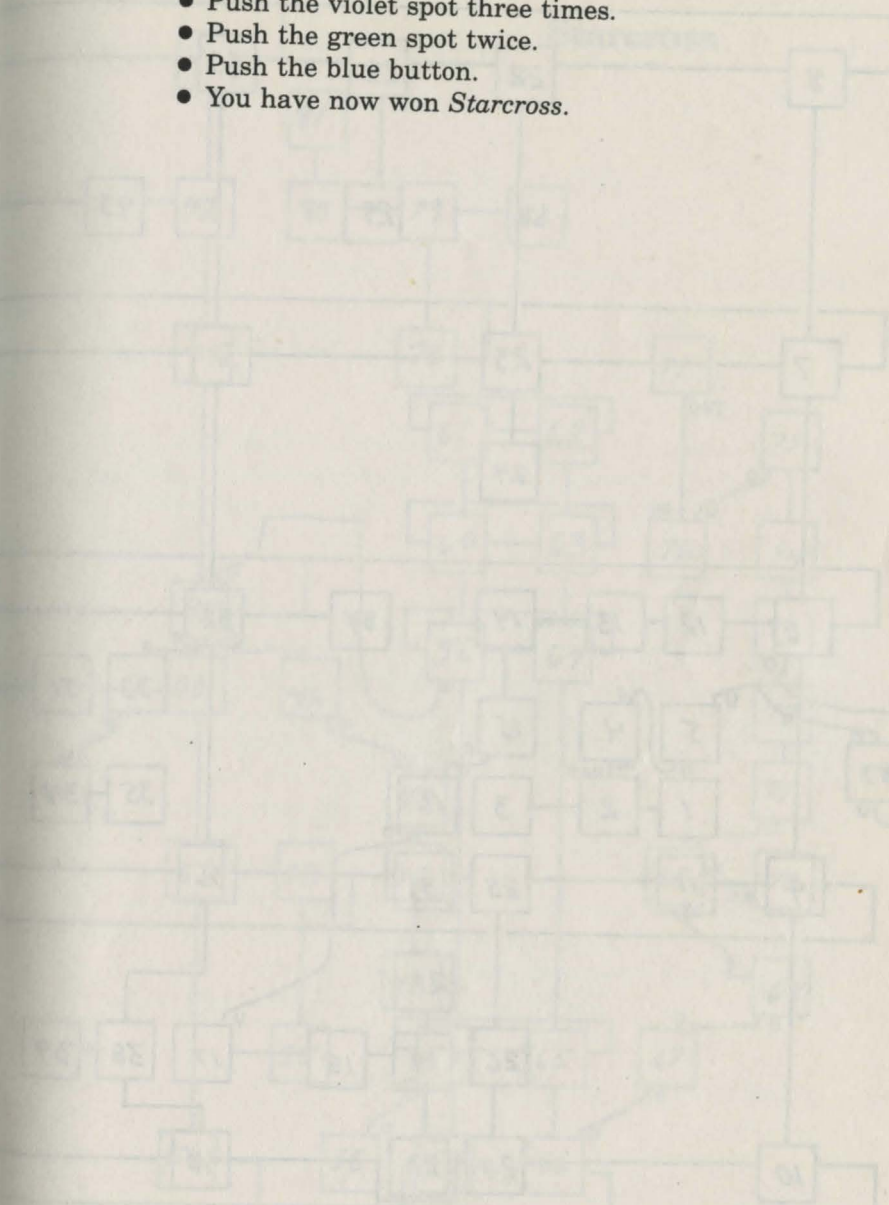

Starcross

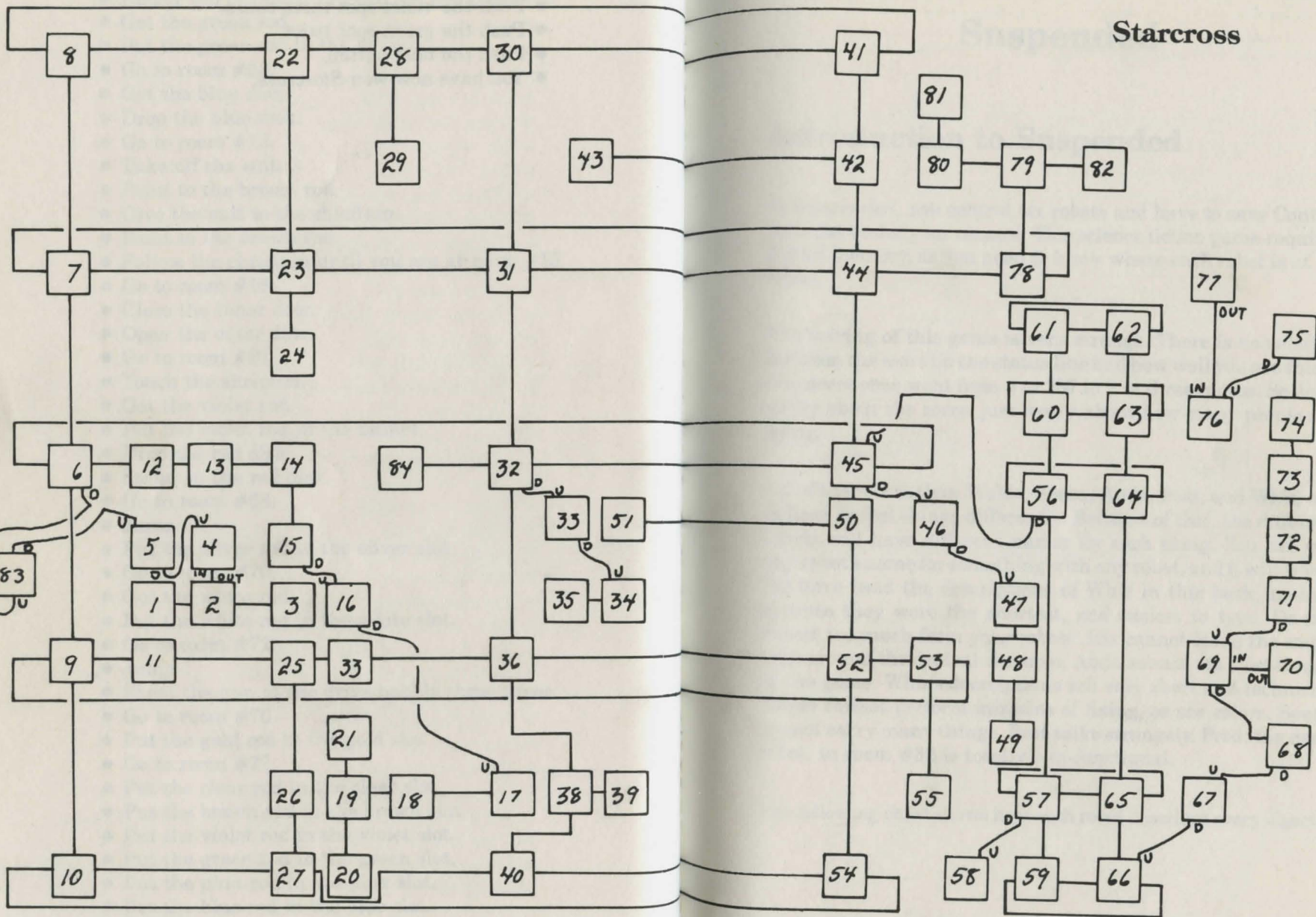

Suspended

Introduction to Suspended

In *Suspended*, you control six robots and have to save Contra, a planet under your control. This science fiction game requires a good memory, as you need to know where each robot is at all times.

The scoring of this game is very strange. There is no relation between the score on the status line and how well you are doing. Our score once went from 3 to 257 to 2 in three moves. So don't worry about the score, just worry about how many people are dying.

All of the robots (Iris, Waldo, Sensa, Auda, Poet, and Whiz) see or hear or feel things differently. Because of this, the different robots will have different names for each thing. You can use any robot's name for something with any robot, and it will work. We have used the descriptions of Whiz in this book, mainly because they were the shortest, and easiest to type. Do not expect too much from your robots. Iris cannot leave the small area around the central chamber. Auda cannot see most things in the game. Whiz's descriptions are very short and technical. Waldo cannot perform miracles of fixing, or see colors. Sensa cannot carry many things. Poet talks strangely. Fred, the dead robot, in room #32 is totally non-functional.

The following chart shows how each robot describes every object.

IRIS	WALDO	SENSA	AUDA	POET	WHIZ
micro-surgery extension	usable extension	small object	tinging object	grasper	MH1
	metal panel	transmission barrier		door	MP1
basket	hollow container	small container		basket of goodies	BA1
red ic	smooth object	polarized object		brain zip	RX0
blue ic	rough object	scanning object		brain plain	RX1
yellow ic	bumpy object	filtering object		brain two	RX2
green ic	wavy object	maximized object		brain trio	RX3
plaid ic	pebbled object	buss object		brain quartet	RX4
blue 16-inch cable	16-inch cable	16-inch cable		16-inch cable	16-inch cable
red chip	smooth device	polarized device		brain zero	CX0
blue chip	rough device	scanning device		brain uno	CX1
yellow chip	bumpy device	filtering device		brain dos	CX2
burned chip	disfigured device	ruined device		brain tres	CX3
fried chip	bubbly device	seized device		brain quart	CX4
machine	medium-sized object	strange apparatus		processor	GG1
orange button	raised spot	button		button	B5
red socket	first depression	plus receptacle		primo socket	S1
yellow socket	second depression	negative socket		secondary socket	S2
steep ramp	slanting object	object		slanting wedge	W1
tall column	hollow column	electrical column	column	sweet home	CPU
	walkway	conveying mechanism	noisy walkway	glider	BLT
	large object	large object		cage	CB3
		flowswitch		flowswitch	
	broken mechanism	broken device	broken construct	FRED	un-tagged device
red 12-cable	smooth wire	conductor	12-inch cable	12-inch cable	12-inch cable
television camera	small sphere	transmitter		sender	TV1
	large hollow object	egg-shaped object	large object	carriage	CAR
glass fuse	small cylinder	glass fuse		glass interrupter	GF1
pair of cutters	cutting tool	metal tool		life slicer	CU1
tool bag	tiny container	tool container	jungling bag	tool bag	TB
	square container	strange container		big brother	C9
	high extending holder	stable holder		furthest holder	TS

General Hints

Do not send Auda to do anything except steal the TB because she cannot see anything.

If you are using the CONFIGURE command, the best configuration is to have Waldo start in the middle supply room, have Iris start in the main supply room, have SenSA start in gamma repair, have Whiz start in the weather controls, have Poet start in the sub supply room, and have Auda start in the gamma repair. Have the surface-side systems tremor at a cycle of 100, the cooling systems tremor at a cycle of 100, and the humans arrive at 150. Using this configuration, you can win in 65 moves.

To speak to a robot, say "robot name, action." EXAMPLE: "IRIS, LOOK AT WALDO."

Room Notes

- Main supply room**—There are two sockets here. The S1 socket contains a CX3 chip, and the S2 contains a CX4 chip. One of the robots must replace the CX3 with the RX0, and the CX4 with the RX2. There is also a button here. After you replace the chips with the ICs, you push the button and the GG-1 will open. You must have one of the robots (not Auda) get the fuse, get the cable, and put the fuse back. You now have the orange cable used in room #29.

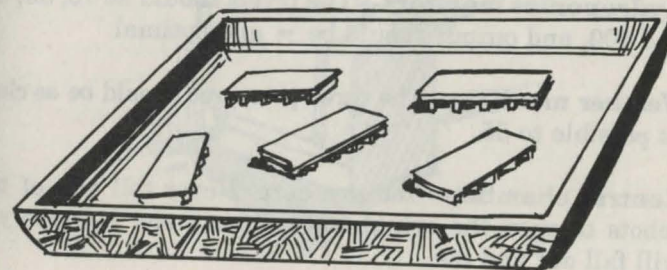

2. **Middle supply room**—There is a 16-inch cable here. It is not useful for anything. The MH1 is for Waldo. He must wear it, and then he can fix Iris. To fix Iris, he must have the RX1 IC, which is in this room. Tell him to open Iris, replace the CX1 chip with the RX1 IC and close Iris. Iris can now see. The basket contains all the RX ICs (0-4). The RX0 and RX2 ICs are used in room #1, but the other two are useless.
3. **Sub supply room**—There is a W1 here. It is used in two places. First, it is used to put in the drop-off from room #10 to room #39. Next it must be used in room #53. Directions for use there are in the description of that room. There is also a platform here. If you move it, you will find a flat container with a BUC inside. The BUC is unusable, so you can leave it there.

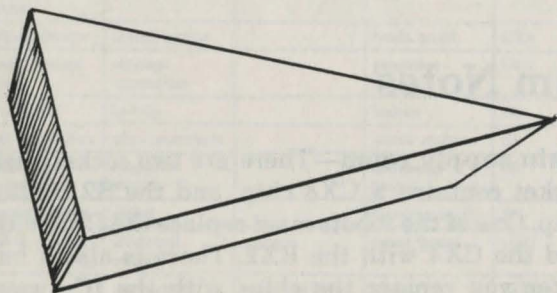

4. **Transit monitors**—Iris can come here to monitor the transit situation aboveground, but there is nothing important here.
5. **Hydroponics monitors**—The levels should be 70, 30, 50, and 100, and output should be = and optimal.
6. **Weather monitors**—The three pressures should be as close as possible to 55.
7. **Central chamber**—You are here. Never tell any of the robots to open the cylindrical column here, because you will fall out and die.

8. **Angling corridor**—There is nothing important here.
9. **Bending corridor**—There is nothing important here.
10. **Hallway junction**—You must put the W1 in the drop-off before you can go north to room #39.
11. **Outer library**—There is nothing important here.
12. **Southeast junction**—There is nothing important here.
13. **Southeast passage**—There is nothing important here.
14. **Bending passage**—There is nothing important here.
15. **Short corridor**—There is nothing important here.
16. **Rising passage**—There is nothing important here.
17. **Top passage**—There is nothing important here.
18. **Index peripheral**—If Whiz queries something here, it will tell him which other peripherals have information on that subject.
19. **Historical peripheral**—This peripheral will give historical information on all subjects it can.

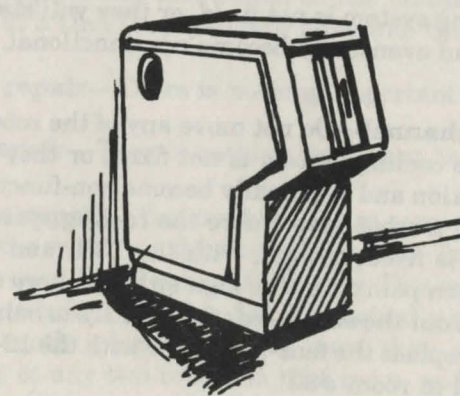

20. **Technical peripheral**—This peripheral will give technical background on objects and how to use them.
21. **Advisory peripheral**—This peripheral gives information on why you need to use each of the objects.
22. **Central core**—There is nothing important here.
23. **Cavernous room**—Do not move any of the robots to this room if the cooling system is not fixed, or they will start to malfunction and eventually become non-functional.
24. **East end**—Do not move any of the robots to this room if the cooling system is not fixed, or they will start to malfunction and eventually become non-functional.
25. **Alpha FC**—Do not move any of the robots to this room if the cooling system is not fixed, or they will start to malfunction and eventually become non-functional.
26. **Beta FC**—Do not move any of the robots to this room if the cooling system is not fixed, or they will start to malfunction and eventually become non-functional.
27. **Gamma FC**—Do not move any of the robots to this room if the cooling system is not fixed, or they will start to malfunction and eventually become non-functional.
28. **Primary channel**—Do not move any of the robots to this room if the cooling system is not fixed, or they will start to malfunction and eventually become non-functional. You must bring a robot here before the cooling system breaks or after it is fixed, though, with the TV1, and plug it in. You can then point it at the sign either in here or in room #29 to find out the access code for the FC's to balance. Then you must replace the four-inch cable with the 12-inch cable (from Fred in room #32).

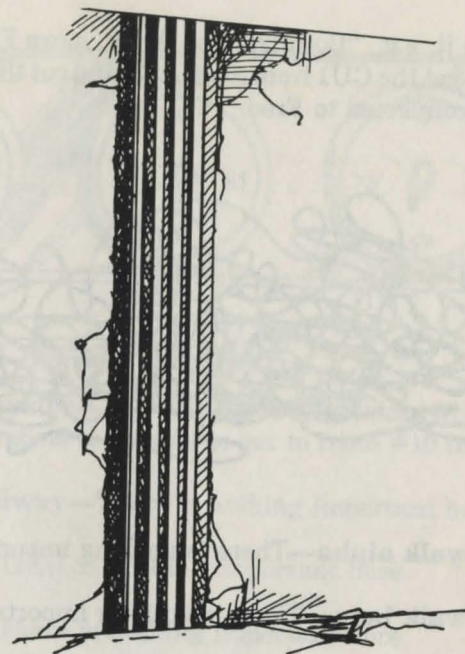

29. **Secondary channel**—Do not move any of the robots to this room if the cooling system is not fixed, or they will start to malfunction and eventually become non-functional. You must come here before the cooling system breaks or after the cooling system is fixed and replace the nine-inch cable with the 14-inch cable from room #1. After you have replaced both cables, you can have a robot go to the main supply room and punch in the access codes (three letters at a time) and you will have won the game.
30. **Alpha repair**—There is nothing important here.
31. **Beta repair**—There's nothing important here.
32. **Gamma repair**—You can have Sensa come here, and she will find a switch on the front of the CB3. Tell her to turn it, and you will find miles of circuitry. This is an untagged device, according to Whiz, but it is actually your near and dear seventh robot, Fred. You must then make a dual-cryolink to any two robots in that room, and tell them to

move it, e.g., "Both Iris and Auda, move Fred." Then you must get the CU1 from room #53, and cut the 12-inch cable. It is connected to Fred.

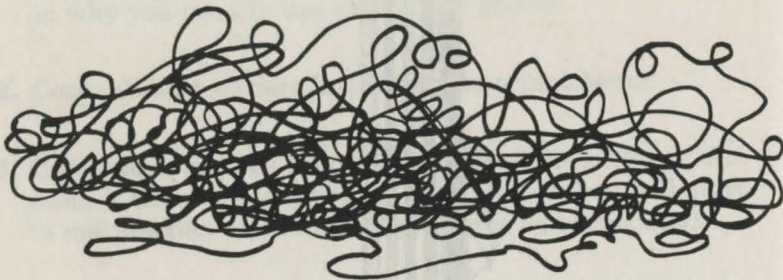

33. **Skywalk alpha**—There is nothing important here.
34. **Skywalk beta**—There is nothing important here.
35. **Skywalk gamma**—There is nothing important here.
36. **Transit control area**—One of the earthquakes makes the manual controls for hydroponics and transit controls malfunction. When it does, have a robot other than Auda come here and turn each of the three switches.
37. **Hydroponics control area**—One of the earthquakes makes the manual controls for hydroponics and transit controls malfunction. When it does, have one of the robots other than Auda come here and reset the levers in the following manner. Set the first lever to 90, the second lever to 45, and the third to 70.
38. **Weather control area**—At the beginning of the game this place is messed up. After you have fixed Iris, you can take her to the weather monitors; the first and third tower pressures will be at 55, and the second will probably be somewhere below that. Have one of the other robots come here and set the second dial to 100. You should do this as soon as possible, to save yourself from any more casualties.

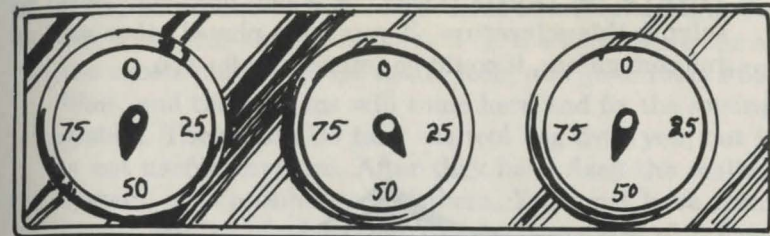

39. **Sloping corridor**—The W1 must be positioned in the drop-off for any robots to be able to get to room #10 from here.
40. **Access hallway**—There is nothing important here.
41. **Hallway**—There is nothing important here.
42. **Hallway**—There is nothing important here.
43. **Hallway T**—There is nothing important here.
44. **Dead end**—There is nothing important here.
45. **Hallway**—There is nothing important here.
46. **Hallway corner**—There is nothing important here.
47. **Hallway branch**—There is nothing important here.
48. **Library entrance**—There is nothing important here.
49. **Hallway end**—To get from here to room #58, you must have a robot get into the CAR. Only one robot can be in that area at a time.
50. **Sterilization chamber**—This is where the humans enter. There is a plaque here. The only robot that can read it is the only robot that can read, Iris. If you have any other robot read it, you will get nonsense. For instance, if you have Auda read it, she will answer that it says "TING

TINKLE DE DONG TONG." It is not, however, useful in solving this adventure. If you have played other earlier Infocom games, it could be interesting for you.

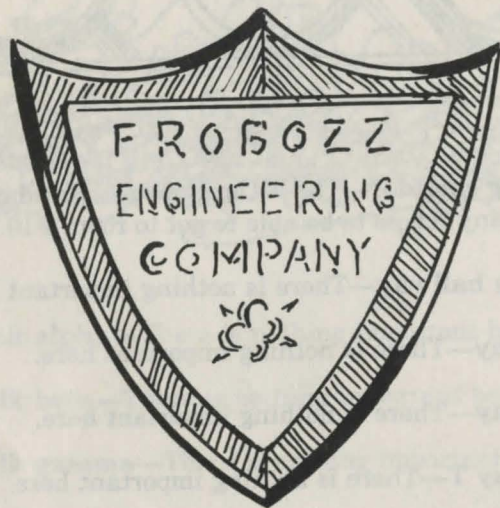

51. **Decontamination chamber**—There is nothing important here.
52. **Entry area**—There is nothing important here.
53. **Small supply room**—There are two things here. First, you must bring the W1 here, have a robot stand on it, and he (or she or it) can then get the CU1 off of the TS. Also, when the humans come by here, they will open up the C9 and get out the TB. It is the means by which you fix the cooling system. The explanation is in room #55.
54. **Activities area**—After you have followed the directions for the next room, the humans will come here and play *Starcross*.

55. **Sleep chamber**—The humans come here after getting the TB. They just happen to leave it on the floor. Have one of the robots pick it up. Go south, look, and go to room #56. Wait, and the humans will come here and fix the cooling system. They will also take the tool bag from you, but it is not useful anymore. After they have fixed the cooling system, it is possible to kill them. You must have them second in a list of robots, e.g., "Auda, Humans, look." They will not respond, but the cryolink will be established to them. Just say "Kill self," and they do. Of course, you don't have to wipe them out, but it's fun!

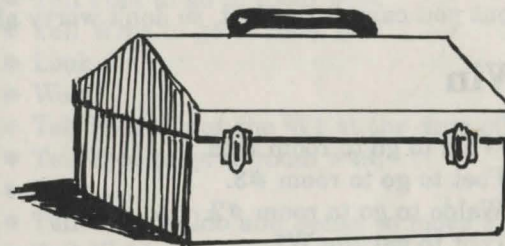

56. **Maintenance access**—Lure the humans here with the TB, and they will fix the cooling system for you.
57. **Library core**—There is nothing important here.
58. **Vehicle debarkation area**—You must get in the CAR to get from here to room #49.
59. **Biology corridor**—There is nothing important here.
60. **Biology laboratory**—There is a TV1 here. It is to be plugged in at either the primary or secondary channel, and it can be pointed at things, such as the grooves or the signs.

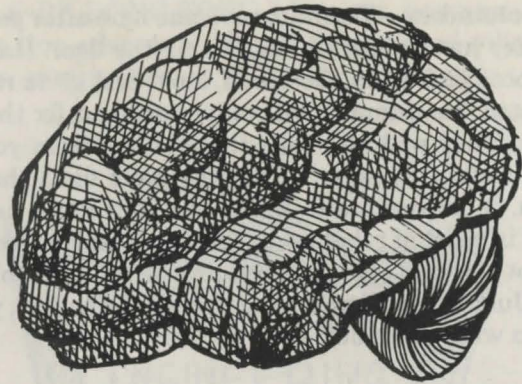

61. **Cryogenic area**—There is a bar here extending high on the wall, but you cannot reach it, so don't worry about it.

How to Win

- Tell Whiz to go to room #38.
- Tell Poet to go to room #3.
- Tell Waldo to go to room #2.
- Tell Poet to get the W1.
- Tell Poet to go to room #10.
- Tell Iris to go to room #1.
- Tell Sensa to go to room #32.
- Tell Auda to go to room #55.
- Tell Auda to listen.
- Look.
- Tell Whiz to set the second dial to 100.
- Tell Poet to put the W1 at the drop-off.
- Tell Poet to go north.
- Tell Poet to get the W1.
- Tell Poet to go to room #53.
- Tell Waldo to get the BA1, MH1.
- Tell Waldo to wear the MH1.
- Tell Waldo to go north.
- Tell Waldo to replace the CX3 with the RX0.
- Tell Waldo to replace the CX4 with the RX2.
- Tell Waldo to open Iris.

- Tell Waldo to replace the CX1 with the RX1.
- Tell Waldo to close Iris.
- Tell Waldo to push the B5.
- Tell Waldo to get the GF1, 14-inch cable.
- Tell Waldo to put the GF1 in the machine.
- Tell Waldo to drop all but the MH1, 14-inch cable.
- Tell Poet to drop the W1.
- Tell Poet to climb the W1.
- Tell Poet to get the CU1.
- Tell Poet to go down.
- Tell Poet to drop the CU1.
- Tell Waldo to go to room #32.
- Tell Sensa to look at the CB3.
- Tell Sensa to turn the flow switch.
- Tell Poet to get the W1.
- Tell Poet to go to room #39.
- Tell Whiz to go to room #37.
- Look.
- Wait.
- Tell Poet to put the W1 at the drop-off.
- Tell Poet to go to room #49.
- Wait.
- Tell both Waldo and Sensa to move FRED.
- Tell Waldo to go to room #53.
- Tell Sensa to go to room #36.
- Look.
- Tell Poet to get in the CAR.
- Tell Poet to get out.
- Tell Poet to go to room #60.
- Wait.
- Tell Poet to get the TV1.
- Tell Poet to go to room #58.
- Wait.
- Tell Poet to get in the CAR.
- Tell Poet to get out.
- Tell Poet to go to room #15.
- Tell Waldo to get the CU1.
- Tell Waldo to go to room #32.
- Wait twice.
- Tell Sensa to turn the first switch.
- Tell Sensa to turn the second switch.

- Tell Sensa to turn the third switch.
- Tell Whiz to set the first lever to 90.
- Tell Whiz to set the second lever to 45.
- Tell Whiz to set the third lever to 70.
- Tell Waldo to cut the 12-inch cable with the CU1.
- Tell Waldo to drop the CU1.
- Tell Waldo to get the 12-inch cable.
- Tell Waldo to go to room #15.
- Wait eight times.
- Tell Auda to get the TB.
- Tell Auda to go south.
- Tell Auda to look.
- Tell Auda to go south.
- Tell Auda to go east.
- Wait.
- Tell Waldo, Poet to go to room #28.
- Wait twice.
- Tell Waldo to replace the four-inch cable with the 12-inch cable.
- Tell Poet to plug the TV1 in.
- Tell Waldo to go to room #29.
- Wait.
- Tell Waldo to replace the nine-inch cable with the 14-inch cable.
- Tell Poet to point the TV1 at the sign.
- Tell Iris to push the first three letters of the transmission.
- Tell Iris to push the last three letters of the transmission.
- You have now won *Suspended*.

Suspended

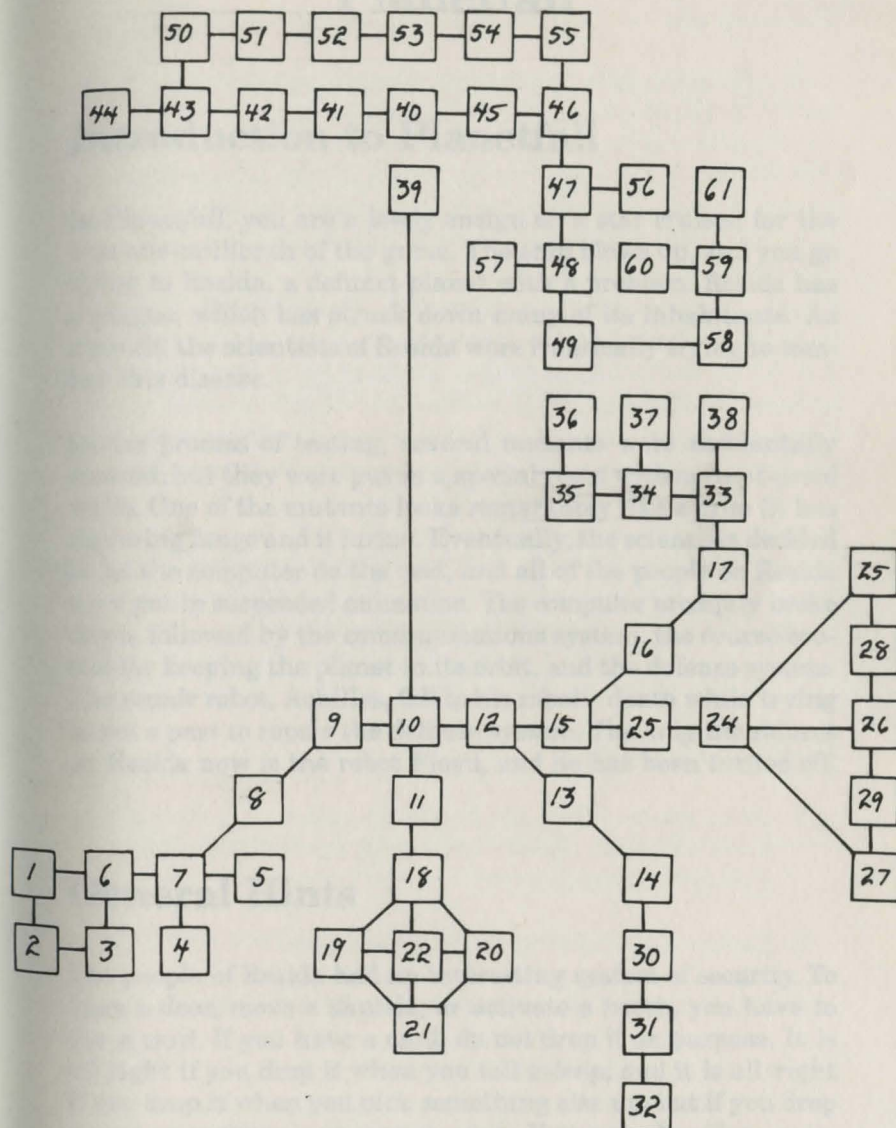

Planetfall

Introduction to Planetfall

In *Planetfall*, you are a lowly ensign on a star cruiser, for the first one-millionth of the game. The ship blows up, and you go flying to Resida, a defunct planet with a problem. Resida has a plague, which has struck down many of its inhabitants. As a result, the scientists of Resida were frantically trying to combat this disease.

In the process of testing, several mutants were accidentally created, but they were put in a special room with mutant-proof walls. One of the mutants looks remarkably like a grue (it has slavering fangs and it lurks). Eventually, the scientists decided to let the computer do the rest, and all of the people on Resida were put in suspended animation. The computer promptly broke down, followed by the communications system, the course control for keeping the planet in its orbit, and the defense system. The repair robot, Achilles, fell to his robotic death while trying to get a part to repair the defense system. The only inhabitant on Resida now is the robot Floyd, and he has been turned off.

General Hints

The people of Resida had an interesting system of security. To open a door, move a shuttle, or activate a booth, you have to use a card. If you have a card, do not drop it on purpose. It is all right if you drop it when you fall asleep, and it is all right if you drop it when you pick something else up, but if you drop a card on purpose, you cannot use it. Your patrol uniform originally contains an ID card, but you can get rid of it, since it isn't necessary. The uniform can contain three cards at once.

To activate a booth, or open a door, slide the correct card through the slot.

The cards are:

- Kitchen (use in room #24).
- Lower elevator (use in room #60).
- Miniaturization (use in room #89).
- Shuttle (use in rooms #64, #65, #68, #69).
- Teleportation (use in rooms #16, #53, #87).
- Upper elevator (use in room #54).

There are three robots in *Planetfall*. The first, and most important, is Floyd. Floyd is a good friend. The second is Achilles. If Achilles had not been broken he could have fixed the planet by himself. The last robot is Lazarus, Floyd's medical buddy. Lazarus is gone; all that remains of him is a breastplate. The only robot with a use is Floyd. You must kill him in room #96.

In room #85 is a computer terminal. If you turn it on, you will learn things about Resida and Infocom. It is useless, but it is fun to hear Floyd say that he won all the puzzles in *Zork I* except that he never could get into the white house.

Room Notes

1. **Deck nine**—When the Feinstein gets shot, a door to the west will slide open. Go through it, and follow the instructions there.
2. **Gangway**—Nothing is important here.
3. **Deck eight**—If you are here, Blather will start screaming at you to go to your station (room #1). If you do aggressively insubordinate things like throwing the brush at Blather, or not returning to room #1, you will get thrown into room #5.
4. **Reactor lobby**—See the instructions for room #3.

5. **Brig**—If you are here, you will die very soon (when the ship blows up). You may as well QUIT or RESTART because there's no way you're going to get any points (or, for that matter, live!) on this run.

6. **Escape pod**—You should come in here when the ship blows up. When you first get here, get in the webbing until the pod hits Resida (the planet). Then get out and get the kit which appears when you land on the planet. The kit contains food that you will need to survive, at least until you get to room #25. This food will only last for one day, so be careful. After you get the kit, open the door and go up.

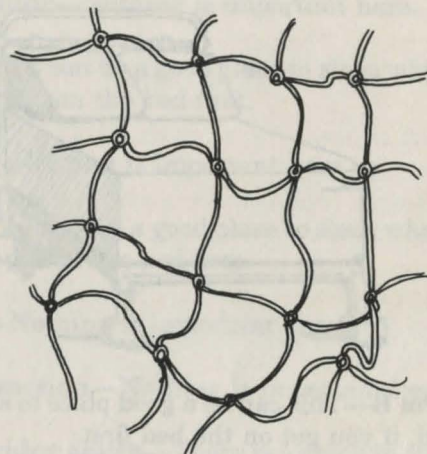

7. **Underwater**—If you do not go up, you will die. Do not come down here after you have gotten to land.
8. **Crag**—Nothing is important here.
9. **Balcony**—Nothing is important here.
10. **Winding stair**—Nothing is important here.
11. **Courtyard**—Nothing is important here.
12. **West wing**—Nothing is important here.

13. **Plain hall**—Nothing is important here.
14. **Rec area**—The games delight Floyd (the robot in room #51), but they are not important. The lock's combination can be found in room #91, but it isn't very important.
15. **Conference room**—Nothing is important here.
16. **Booth 1**—If you have the teleportation card (room #91), you can go to either room #53 or room #87. Read the instructions in room #91 to find out how.
17. **Rec corridor**—Nothing is important here.

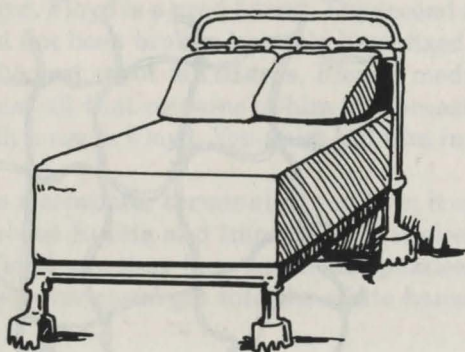

18. **Dorm B**—This can be a good place to sleep when you are tired, if you get on the bed first.
19. **SanFac B**—Nothing is important here.
20. **Dorm A**—This can be a good place to sleep when you are tired, if you get on the bed first.
21. **SanFac A**—Nothing is important here.
22. **Mess corridor**—The way to open the lock is long and complicated. It is also necessary. The crack in room #32 contains a key. The only way to get it out is to follow the directions there. The key will unlock the lock, and you will be able to unlock it and go north. *Warning:* Do not use the laser on the lock; it will just fuse it shut.

23. **Storage west**—There is no way to open the can. Don't try. The ladder can only be carried if everything you were carrying (not wearing) has been dropped. Bring the ladder to room #34 and follow those instructions.
24. **Mess hall**—You need the kitchen card from room #39 to go south. The canteen is needed in room #25.
25. **Kitchen**—The machine is a food and drink producer. Put the canteen under the spout (open the canteen first) and push the button. You now have some delicious brown stuff that quenches thirst and hunger at the same time.
26. **Dorm corridor**—Nothing is important here.
27. **Dorm D**—This can be a good place to sleep when you are tired, if you get on the bed first.
28. **SanFac D**—Nothing is important here.
29. **Dorm C**—This can be a good place to sleep when you are tired, if you get on the bed first.
30. **SanFac C**—Nothing is important here.
31. **Corridor junction**—Nothing is important here.
32. **Admin corridor south**—There is a crack in the ground. There is a key in the crack. The only way to get the key is to put the magnet from room #49 on the crack. The key is needed in room #22.

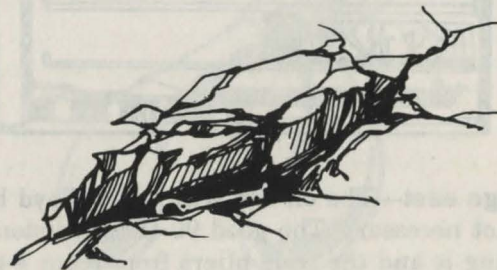

33. **SanFac E**—Nothing is important here.
34. **Admin corridor**—Bring the ladder from room #23 here, drop it, extend it, and put it across the rift. You can now go north.
35. **Systems monitors**—The malfunctioning systems should be fixed.
36. **Admin corridor north**—Nothing is important here.
37. **Transportation supply**—You can't do anything here because there is no light which is safe to get. So don't come up here.
38. **Plan room**—Nothing is important here.
39. **Small office**—Open the desk. There will be two cards there. The first one is the kitchen card. It is needed in room #24. The second is the upper elevator card. It is needed in room #54.
40. **Large office**—Open the desk. There will be one card there. It is the shuttle card. It is needed in room #65, and can be used in rooms #64, #68, and #69.
41. **Mech corridor north**—Nothing is important here.

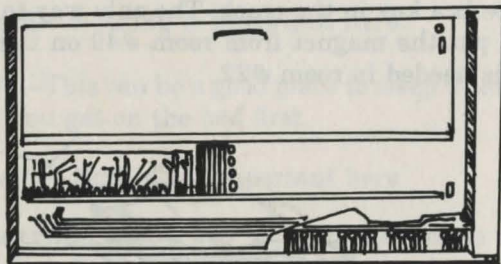

42. **Storage east**—The oil can will make Floyd happy, but it is not necessary. The good 90-ohm bedistor, however, is. Bring it and the wide pliers from room #49 to room

#78, and follow those directions. The K- and B-series megafuses are completely useless (unless, of course, you have a thing for megafuses). The cracked fromitz board is not necessary, either.

43. **Physical plant**—Nothing is important here.
44. **Mech corridor**—Nothing is important here.
45. **Reactor control**—Nothing is important here.
46. **Reactor access stairs**—Forget about getting a light; this is a ruse.
47. **Reactor elevator**—There is no reactor elevator card that you can get, so don't bother (besides, the monitors in room #35 say the reactor is fine, so why bother?).
48. **Mech corridor south**—Nothing is important here.
49. **Tool room**—The flask is used in room #50 for room #57. The laser is used in rooms #100 and #101. Take the old battery out, and put the new battery from room #91 in. The pliers are needed along with the good 90-ohm bedistor (room #42) in room #78.

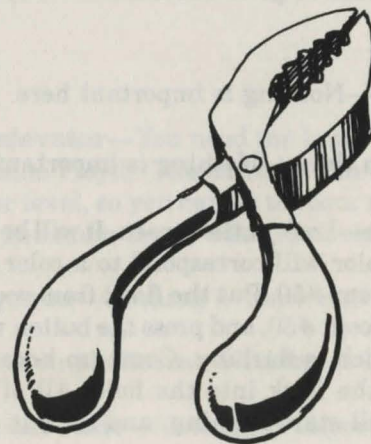

50. **Machine shop**—This room will be used in the process of fixing the broken, dead communications. The spout dispenses chemicals. Push the button for the Catalyst, Coolant, Acid, or Base that you want. The use for this will be explained in room #57.
51. **Robot shop**—There is a robot here. His name is Floyd. If you open him, you will get the lower elevator card. This is needed in room #60. Once he 'lives,' you will have to turn him off to get the card. If you turn him on, and wait awhile, he will come to life. He is a friend, but he has a use. Take him to room #88, then to room #96, and follow those instructions.
52. **Elevator lobby**—Push the red button and wait to open the red door; push the blue button and wait to open the blue door.
53. **Booth 2**—If you have the teleportation card (room #91), you can go to either room #16 or room #87. Read the instructions in room #91 to find out how.
54. **Upper elevator**—To do anything here, you will need the upper elevator card from room #39. Follow the standard activation procedure described above, and push the up button to go to the top, so you can go to room #55; push the down button to go to the main level so you can go to room #52.
55. **Tower core**—Nothing is important here.
56. **Observation deck**—Nothing is important here.
57. **Comm room**—Look at the screen. It will be flashing some color. This color will correspond to a color on one of the buttons in room #50. Put the flask from room #49 under the spout in room #50, and press the button which matches the color which is flashing. Come up here and pour the liquid from the flask into the hole. All of the lights on the board will start flashing, and all but one will stop.

This light will match another button in room #50. Repeat the preceding actions until *Planetfall* says that the message is being sent. Now you can go down to the main level and drop the upper elevator card, as the entire upper level has been solved.

58. **Helipad**—Nothing is important here.
59. **Helicopter**—This place is a fake. There is no way to fly, move, or do anything else to this helicopter. Forget about it.

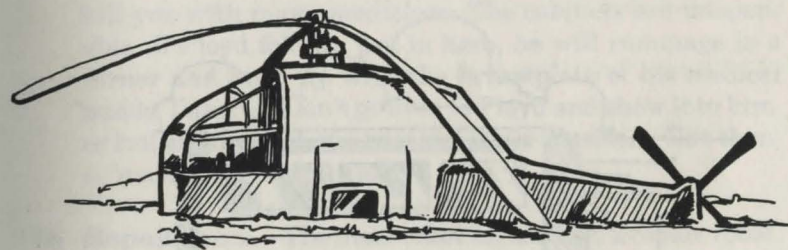

60. **Lower elevator**—You need the lower elevator card here (from inside Floyd). The down button causes you to be at the lower level, so you can go to room #61. The up button leads to the main level, where you can go to room #52.
61. **Waiting area**—Nothing is important here.
62. **Kalamontee platform**—Nothing is important here.
63. **Shuttle car Alfie**—Nothing is important here.

64. **Alfie control west**—You need the shuttle card (room #40) here. Once you activate the shuttle, push the lever up. You will start moving. Push the lever down once (into neutral) when you reach 45. Look or wait six times and push the lever down again. You will slide into Kalamontee neatly. *Note*—Only use this end of the shuttle when going from Lawanda (room #66) to Kalamontee (room #62).
65. **Alfie control east**—You need the shuttle card (room #40) here. Once you activate the shuttle, push the lever up. You will start moving. Push the lever down once (into neutral) when you reach 45. Look or wait six times and push the lever down again. You will slide into Lawanda neatly. *Note*—Only use this end of the shuttle when going from Kalamontee (room #62) to Lawanda (room #66).

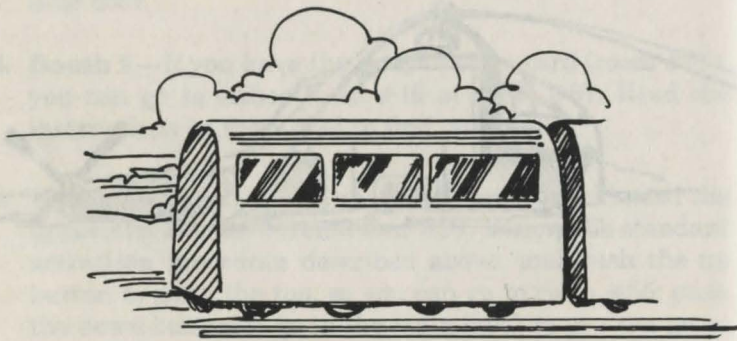

66. **Lawanda platform**—You have now reached the 'other' complex on Resida.
67. **Shuttle car Betty**—Nothing is important here.
68. **Betty control west**—You need the shuttle card (room #40) here. Once you activate the shuttle, push the lever up. You will start moving. Push the lever down once (into neutral) when you reach 45. Look or wait six times and push the lever down again. You will slide into Lawanda neatly. *Note*—Only use this end of the shuttle when going from Kalamontee (room #62) to Lawanda (room #66).

69. **Betty control east**—You need the shuttle card (room #40) here. Once you activate the shuttle, push the lever up. You will start moving. Push the lever down once (into neutral) when you reach 45. Look or wait six times and push the lever down again. You will slide into Kalamontee neatly. *Note*—Only use this end of the shuttle when going from Lawanda (room #66) to Kalamontee (room #62).
70. **Escalator**—Nothing is important here.
71. **Fork**—Nothing is important here.
72. **Systems corridor west**—Nothing is important here.
73. **Infirmary**—The medicine is harmless, but not helpful. Do not sleep on the bed. A medical robot will come in and kill you with many medicines. The cabinets are unopenable. If Floyd follows you in here, he will rummage in a corner and come up with the breastplate of his medical buddy, Lazarus. Don't go over to Floyd and show it to him, or fool around with the breastplate; it is useless. But then, it 'matures' Floyd a little.
74. **Repair room**—The dead robot is Achilles, a repair robot. (You know, if he hadn't fallen, you wouldn't have to do anything here on Resida. But, that would make a dull game, wouldn't it?). Only Floyd can get through the door. Tell him to, and he will spend an amazing amount of time bouncing a ball in there. When he comes out, tell him to give you the shiny fromitz board. Kindly, he does. Go to room #76 and follow those directions.

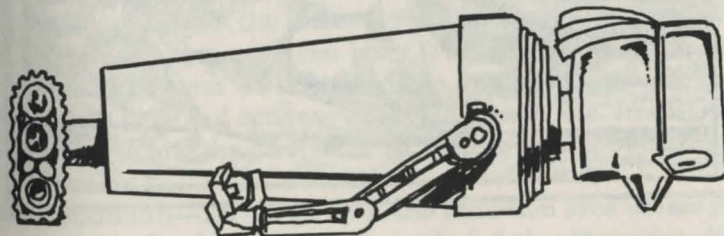

75. **Systems corridor**—Nothing is important here.
76. **Planetary defense**—You should have the shiny fromitz board from room #74 with you. If you don't, go get it. Open the panel and get the second board. Put the shiny board in its place. Close the panel.
77. **Systems corridor east**—Nothing is important here.
78. **Course control**—You should have the good 90-ohm bedistor from room #42 and the pliers from room #49. If you don't, you cannot save the planetary course control yet. If you do, open the cube, get the fused bedistor with the pliers, and put the good bedistor in the cube. Close the cube, and the course is set.
79. **Physical plant**—Nothing is important here.
80. **Project corridor west**—Nothing is important here.
81. **SanFac F**—Nothing is important here.
82. **Project corridor**—Nothing is important here.
83. **ProjCon office**—The mural is very important. Come here when the mutants are chasing you at the end of the game, and an elevator will have replaced the mural. Go in, and follow the instructions.

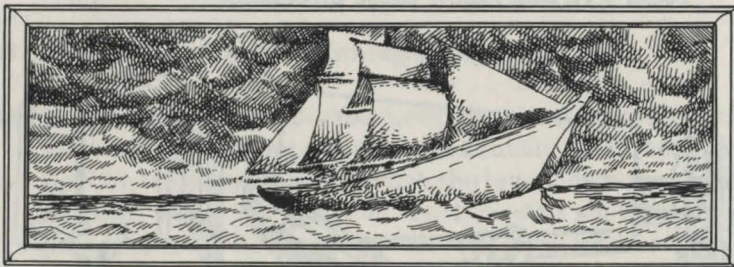

84. **Project corridor east**—Nothing is important here.
85. **Library lobby**—The 'object' is a spool on Resida. It is interesting, but not necessary.
86. **Library**—Put all spools in the reader if you want to read them. Of course, you aren't under any obligation to read them.
87. **Booth 3**—If you have the teleportation card (room #91), you can go to either room #16 or room #53. Read the instructions in room #91 to find out how.
88. **Computer room**—Read the output to learn that sector 384 is damaged. You will have to get Floyd in here to win, so get him in here, and stay here until he realizes the computer is broken.

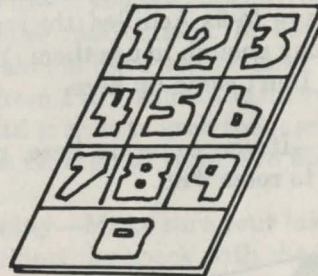

89. **Miniaturization booth**—You need the miniaturization card from room #97 here. Activate the miniaturization processes. Do not continue unless you have corrected the communications in room #57, the planetary defense in room #76, and the planetary course control in room #78. You will also need the laser (room #49), with the new battery (room #91) in it. Once you have done all this, come here and activate the machine and say 'TYPE 384'. Now follow the directions for room #98 and beyond.
90. **Main lab**—Do not go up to the radiation area unless you want a free haircut (all of your hair falls out and you die).

91. **Lab storage**—There is a good laser battery here. Put it in the laser for rooms #100 and #101. If you open the pocket of the lab uniform, you will see a teleportation card and a piece of paper. The paper gives the combination for the lock in room #14. The teleportation card can only be used in rooms #15, #63, and #87. To use it, slide it through the slot in one of those rooms, and push the button that matches the number of the room to which you wish to go. Room #16 is Booth 1, room #70 is Booth 2 and room #87 is Booth 3.
92. **Radiation lock west**—Don't come up here unless you want to die.
93. **Radiation lock east**—You can't open this door unless you have closed the radiation-lock door. If you open this door, you will die.
94. **Radiation lab**—There is a portable lamp here. There is also a spool on how to fix Achilles (the repair robot). You won't be alive long enough to use them. You will soon die from radiation. Don't come up here.
95. **Bio lock west**—If you come up here, make sure that Floyd has been to room #88.

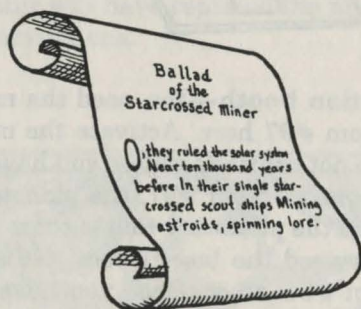

96. **Bio lock east**—If you come up here, make sure that Floyd has been to room #88. Look once, if he has and this is the first time you have been here. Floyd will outline a

plan to get the miniaturization card. Open the door. Close the door. Wait or look. Open the door. Close the door. Floyd will die, but it is very touching. You sing a song about *Starcross*, the first Interlogic Science Fiction Adventure. Get the miniaturization card and head for room #89.

97. **Bio lab**—Do not come in here from the west. If you are in the process of following the instructions for room #103, open the lab door and go west. But then, you should already know that.
98. **Station 384**—If you just got here, set your laser to 1 and go to room #101. If you just got back from there, you are not here. You are in room #102. You are also about to win.
99. **Strip near station**—Nothing is important here.
100. **Middle of strip**—If you are going to room #101, continue and follow those instructions. If, however, you are returning, you should have set the laser from room #49 to any number from 2 to 7. Shoot the microbe. Do that again and again until it tries to grab the laser. Throw the laser over the edge. Now go to room #98 and continue.
101. **Strip near relay**—Make sure your laser is set to 1. Look at the relay. Shoot the speck with the laser until you hit it twice and it dies. Set the laser to some other number, go south and follow those directions.



102. **Auxiliary booth**—Nothing is important here.

103. **Lab office**—If you read the paper, you will have some idea of how to get past the mutants. But you probably don't know all of it. Open the desk, and wear the gas mask. Push the red button, which will fill room #97 with gas. Open the door, go west, open the lab door, go west to room #95, open the door, and go to room #83. Now the mural has disappeared, and you can go south into room #104.

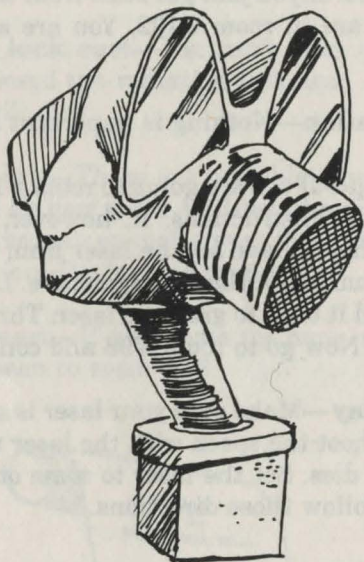

104. **Cryo-elevator**—If the mutants are chasing you, push the button. Now wait until the door opens and go north.

105. **Cryo-anteroom**—If you are here, the game has ended. However, if you haven't won, you should make sure next time that you fix the communications in room #57, the defense in room #76, and the course control in room #78.

How to Win

- Drop the brush.
- Say "WAIT EIGHT TIMES".
- Go to room #6.
- Get in the web.
- Wait 13 times.
- Get up.
- Get the kit.
- Open the door.
- Go to room #42.
- Get the bedistor.
- Go to room #49.
- Get the bar.
- Go to room #32.
- Put the bar on the crevice.
- Drop the bar.
- Go to room #22.
- Unlock the lock with the key.
- Get the lock.
- Drop the lock, key.
- Open the door.
- Go to room #23.
- Drop all.
- Get the ladder.
- Go to room #34.
- Drop the ladder.
- Go to room #23.
- Get the kit, bedistor.
- Eat the red goo.
- Go to room #34.
- Extend the ladder.
- Put the ladder across the rift.
- Go to room #39.
- Open the desk.
- Get the kitchen access card, upper elevator access card.
- Drop the ID card.
- Go to room #40.
- Open the desk.
- Get the shuttle access card.

- Go to room #49.
- Get the flask.
- Go to room #51.
- Open the robot.
- Put all the cards but the upper elevator card in the pocket.
- Go to room #52.
- Push the blue button.
- Wait twice.
- Go to room #54.
- Slide the upper elevator card through the slot.
- Push the up button.
- Wait twice.
- Go to room #57.
- Remember the color of the flashing light.
- Go to room #54.
- Push the down button.
- Wait twice.
- Go to room #27.
- Lie on the bed.
- Wait.
- Get up.
- Get all.
- Go to room #50.
- Put the flask under the spout.
- Push the button that is the same color as the flashing light was.
- Get the flask.
- Go to room #54.
- Slide the upper elevator card through the slot.
- Push the up button.
- Wait twice.
- Go to room #57.
- Pour the liquid into the hole.
- Remember the color of the light that is now flashing.
- Go to room #54.
- Push the down button.
- Wait twice.
- Go to room #50.
- Put the flask under the spout.
- Push the button that is the same color as the flashing light was.

- Get the flask.
- Go to room #54.
- Slide the upper elevator card through the slot.
- Push the up button.
- Wait twice.
- Go to room #57.
- Pour the liquid into the hole.
- Go to room #54.
- Push the down button.
- Wait twice.
- Eat the green goo.
- Go to room #49.
- Drop the flask, upper elevator access card.
- Get the laser, pliers.
- Drop the old battery.
- Go to room #24.
- Get the canteen.
- Slide the kitchen card through the slot.
- Go to room #25.
- Open the canteen.
- Put the canteen under the spout.
- Push the button.
- Get the canteen.
- Close the canteen.
- Go to room #51.
- Eat the brown goo.
- Drop the survival kit.
- Turn the robot on.
- Go to room #52.
- Push the red button.
- Wait three times.
- Go to room #60.
- Slide the lower card through the slot.
- Push the down button.
- Wait three times.
- Go to room #65.
- Slide the shuttle card through the slot.
- Push the lever up.
- Wait eight times.
- Push the lever down.
- Wait six times.

- Push the lever down.
- Wait eight times.
- Go to room #74.
- Tell Floyd to go north.
- Tell Floyd to get the board.
- Go to room #76.
- Open the panel.
- Get the second board.
- Put the shiny board in the socket.
- Close the panel.
- Drop the board.
- Go to room #78.
- Open the cube.
- Get the fused bedistor with the pliers.
- Put the good bedistor in the cube.
- Close the cube.
- Drop the pliers, cube.
- Go to room #91.
- Put the battery in the laser.
- Open the lab pocket.
- Drop the shuttle card, lower card.
- Put the teleportation card in the patrol pocket.
- Go to room #88.
- Wait until Floyd enters the room and says that the computer is broken.
- Go to room #90.
- Open the bio-lock door.
- Go to room #96.
- Look.
- Open the door.
- Close the door.
- Look.
- Open the door.
- Close the door.
- Get the miniaturization card.
- Put the miniaturization card in the pocket.
- Go to room #95.
- Open the door.
- Go to room #89.
- Slide the miniaturization card through the slot.
- Say "TYPE 384".

- Set the laser to 1.
- Go to room #101.
- Look at the relay.
- Shoot the speck with the laser until the speck has been hit twice and is gone.
- Set the laser to 7.
- Go to room #100.
- Shoot the microbe until the microbe tries to get the laser.
- Throw the laser over the edge.
- Go to room #98.
- Go to room #103.
- Open the desk.
- Get the gas mask.
- Wear the gas mask.
- Push the red button.
- Open the door.
- Go to room #97.
- Open the lab door.
- Go to room #95.
- Open the door.
- Go to room #104.
- Push the button.
- Wait until the door opens.
- Go to room #105.
- You have now won *Planetfall*.

Planetfall

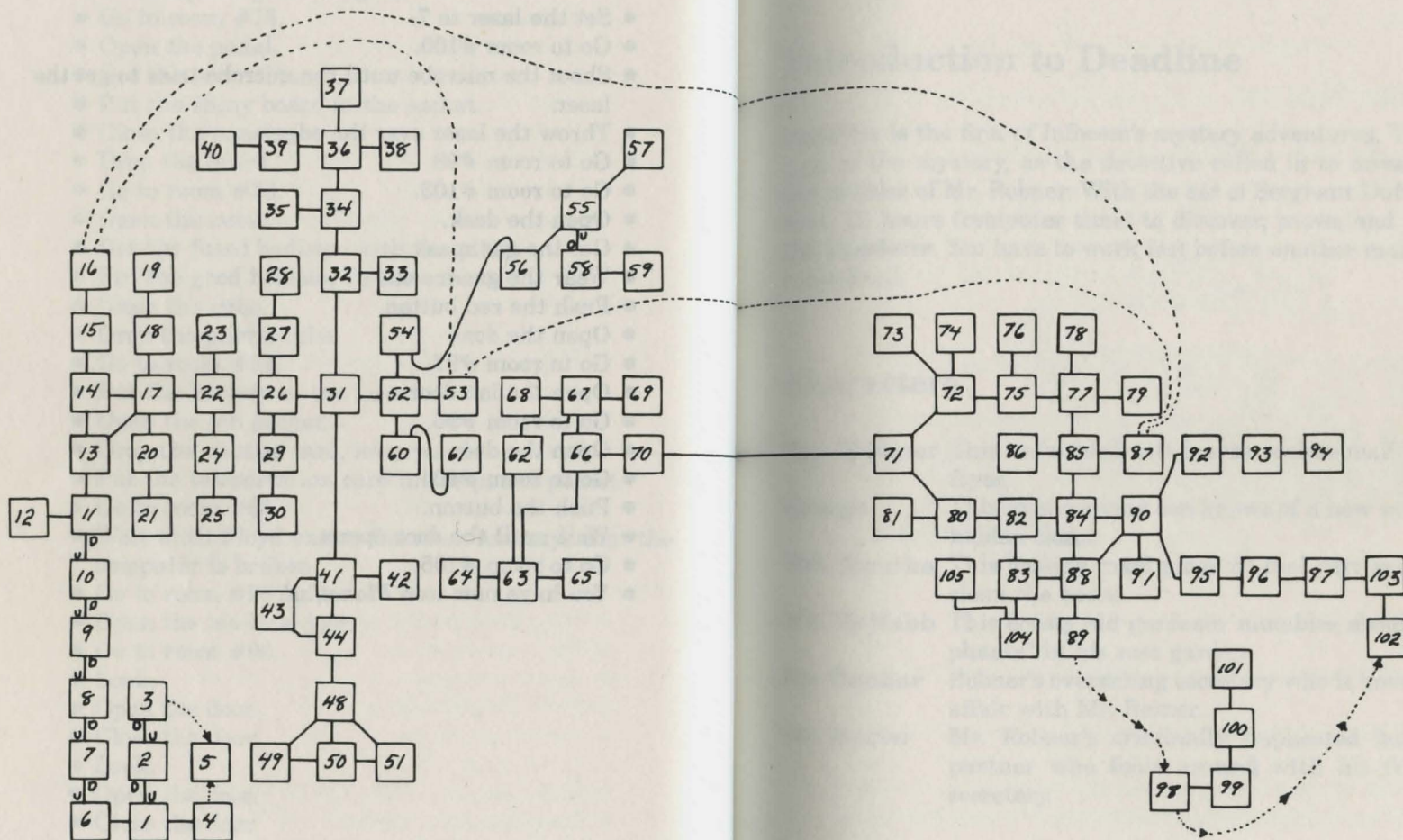

Deadline

Introduction to Deadline

Deadline is the first of Infocom's mystery adventures. You are part of the mystery, as the detective called in to investigate the murder of Mr. Robner. With the aid of Sergeant Duffy, you have 12 hours (computer time) to discover, prove, and arrest the murderer. You have to work fast before another murder is committed.

Characters

- Mrs. Robner** This unfaithful wife leaves useless mail in the foyer.
- George** This music-loving son knows of a new will in a hidden closet.
- Mrs. Rourke** This gossipy maid plays no real part except to clean the house.
- Mr. McNabb** This crusty old gardener mumbles about "elephants" in his rose garden.
- Ms. Dunbar** Robner's overacting secretary who is having an affair with Mr. Baxter.
- Mr. Baxter** Mr. Robner's criminally implicated business partner who fools around with his friend's secretary.

General Hints

Before you can arrest a suspect, you must be able to prove a motive, ample opportunity, and lack of an alibi. If you arrest

a suspect without proper evidence, he (or she) may get away with murder!

Every time you find a new piece of evidence, be sure to examine and analyze it.

Room Notes

1. **South lawn**—Nothing here is important.

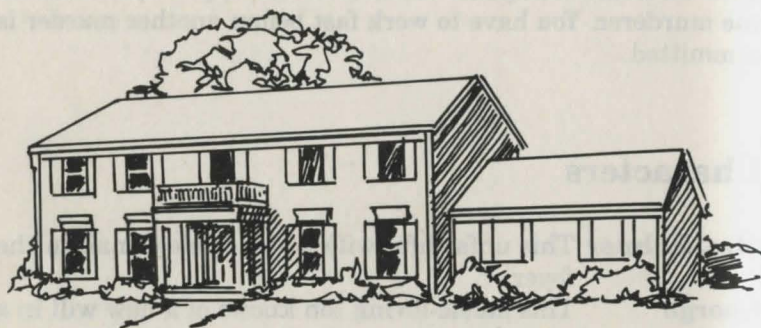

2. **East lawn**—Nothing here is important.
3. **East side of house**—Nothing here is important.
4. **Orchard path**—Nothing here is important.
5. **In the orchard**—If you lean the ladder from room #28 up against the house here, you can climb up to room #35.
6. **Among the roses**—If you wait until McNabb has been to the garden, and then ask him to show you the holes, he will lead you to two rectangular holes in the garden. If you put the ladder in the holes, it will lean perfectly up to room #49. Remove the ladder and dig the earth. If you dig enough, you will find a shard of a cup. Analyze it.

7. **Garden path**—Nothing here is important.
8. **North lawn**—Nothing here is important.
9. **West lawn**—Nothing here is important.
10. **West side of house**—Nothing here is important.
11. **West of front door**—You can get to room #16 if you have opened the window.
12. **Front path**—A newspaper appears here around 11 a.m. Read it carefully. Ms. Dunbar will come here and drop a ticket stub, if you scare her enough (see How to Win). Get the stub and ask her about it.

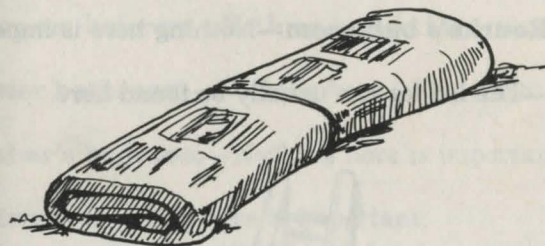

13. **East of front door**—Nothing here is important.
14. **Foyer**—Some time after the newspaper arrives, a letter will arrive. Don't bother with it. It is a red herring.
15. **North of foyer**—Nothing here is important.
16. **Living room**—This is where the will is read. Dunbar and Baxter have a meeting here.
17. **Corner**—Nothing here is important.
18. **Dining room**—Nothing here is important.

19. **Kitchen**—Open the cupboards and count the saucers and plates.
20. **Pantry**—Nothing here is important.
21. **Bottom of stairs**—Nothing here is important.
22. **Stairs**—Nothing here is important.
23. **South hallway**—Nothing here is important.
24. **Mrs. Rourke's room**—Nothing here is important.
25. **South hallway**—Nothing here is important.
26. **South closet**—Nothing here is important.
27. **Mrs. Rourke's bathroom**—Nothing here is important.
28. **Shed**—The ladder can usually be found here.

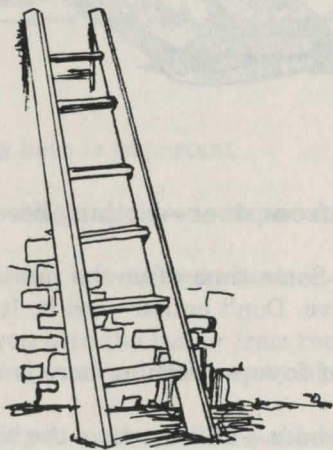

29. **Behind the shed**—Nothing here is important.
30. **Top of stairs**—Nothing here is important.

31. **North upstairs hall**—Nothing here is important.
32. **Guest room**—Nothing here is important.
33. **South upstairs hall**—Nothing here is important.
34. **Dunbar's bathroom**—Open the cabinet and look at the *Lo Blo*.
35. **End of south hall**—Nothing here is important.
36. **Closet**—Nothing here is important.
37. **Hallway**—Nothing here is important.
38. **Master bedroom**—Nothing here is important.
39. **Bedroom balcony**—Nothing here is important.
40. **Master bathroom**—Nothing here is important.
41. **Dunbar's bedroom**—Nothing here is important.
42. **Hallway**—Nothing here is important.
43. **Upstairs closet**—Nothing here is important.
44. **Hallway**—Nothing here is important.
45. **George's bedroom**—Nothing here is important, but you'll usually be able to find George here early in the game.
46. **George's bathroom**—Nothing here is important.
47. **End of hallway**—Nothing here is important.
48. **Library**—Come up here right when you get in the house, and get the pad, the pencil, and the calendar. Shade the pad with the pencil. Drop the pencil. Look at the rug. Turn the page of the calendar. Go to George's room (room #45), and show him the calendar. Drop the calendar.



49. **Library balcony**—Look at the railing. Look at the floor. Hide here when George opens room #50.
50. **Hidden closet**—If you surprise George while he is opening the safe, you should look in the safe, and get the Focus papers.

How to Win

- Go to room #48.
- Get pencil, pad, calendar.
- Shade the pad with the pencil.
- Drop the pencil.
- Turn the page of the calendar.
- Look at the rug.
- Look in the basket.
- Look at the crumpled papers.
- Open the balcony door.
- Go north to room #49.
- Look at the railing.
- Go to room #45.
- Show the calendar to George.
- Go to room #34.
- Open the medicine cabinet.
- Look at the *Lo Blo*.
- Go to room #16.
- Open the window.
- Wait for Baxter.

- Show the pad to him.
- Go to room #12.
- Wait until the newspaper arrives.
- Read it carefully.
- Go to room #16.
- Ask Baxter about Omnidyne.
- Wait until 11:45.
- Go outside and look for McNabb.
- Say "McNabb, show me holes."
- Follow him to room #6.
- Dig the dirt at the holes until you find a piece of porcelain.
- Analyze the fragment for *Lo Blo*.
- Go to room #16.
- Stay there until the will is read.
- Go up to room #49—Pay no attention to what George says.
- Wait 10 minutes.
- Go to room #48.
- Look at the shelves.
- Push the button.
- Look in the safe—Pay no attention to George or the new will.
- Get the papers.
- Go to room #16.
- Show Baxter the papers.
- Show Baxter the lab report.
- Show Dunbar the papers.
- Show Dunbar the lab report.
- Accuse Dunbar.
- Go around to room #11.
- Go north.
- If Dunbar and Baxter suddenly stop talking, wait, and follow Ms. Dunbar when she leaves; otherwise, keep going to room #11, and then north until she does leave.
- Keep following her until she drops a ticket stub in room #12.
- Get the stub.
- Ask Dunbar about the stub.
- Go to room #16.

- Ask Baxter about the stub.
- Go to room #19.
- Count the saucers.
- Count the plates.
- Count the cups.
- Go to room #4.
- Get the ladder.
- Go to room #6.
- Look at the ladder.
- Put the ladder in the holes.
- Go up.
- Arrest Dunbar and Baxter.
- You have now won *Deadline!*

Upper Floor

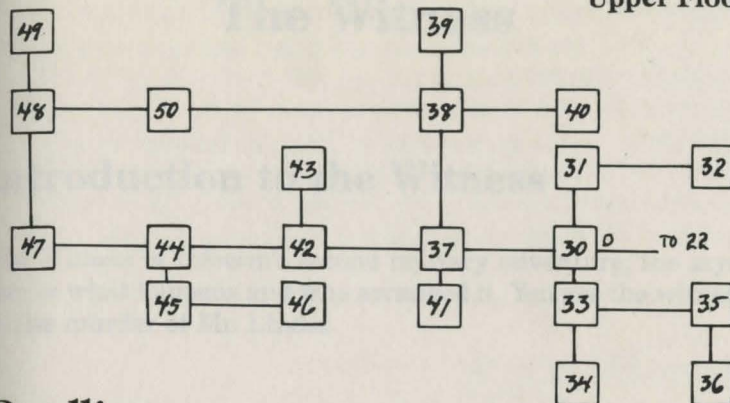

Deadline

Lower Floor

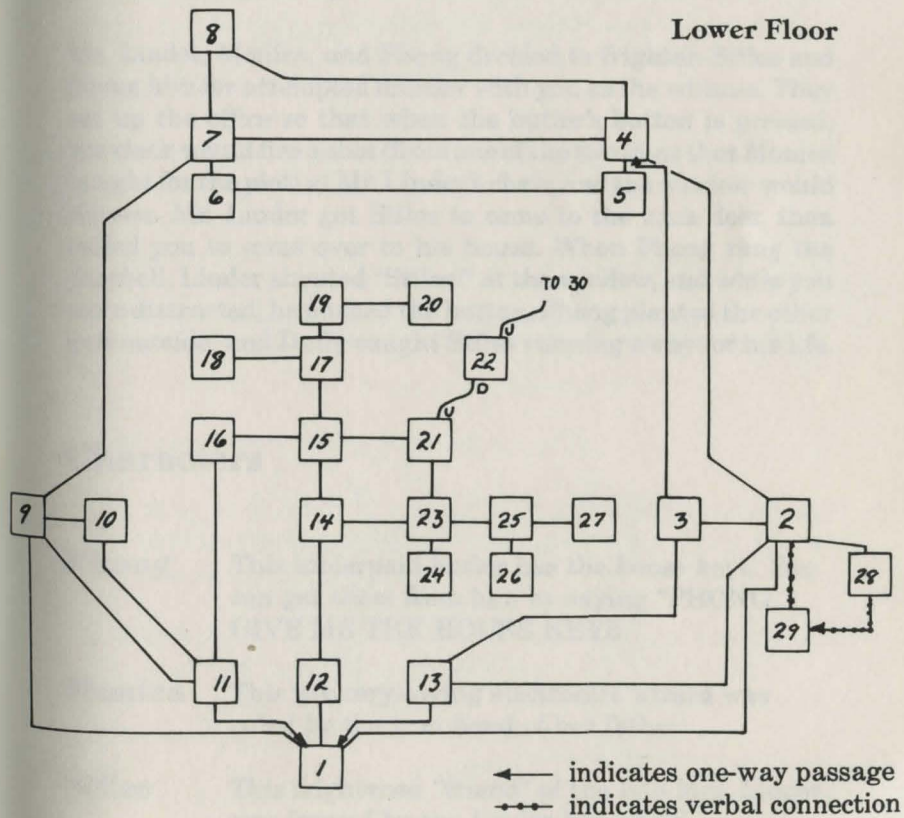

The Witness

Introduction to the Witness

The Witness is Infocom's second mystery adventure; the mystery is what happens and who arranged it. You are the witness to the murder of Mr. Linder.

The Conspiracy

Mr. Linder, Monica, and Phong decided to frighten Stiles and frame him for attempted murder with you as the witness. They set up the office so that when the butler's button is pressed, the clock would fire a shot (from one of the two guns that Monica bought for the plot) at Mr. Linder's chair, and the window would shatter. Mr. Linder got Stiles to come to the back door, then called you to come over to his house. When Phong rang the doorbell, Linder shouted "Stiles!" at the window, and while you were distracted, he pushed the button. Phong planted the other gun outside, and Duffy caught Stiles running away for his life.

Characters

Phong This underpaid butler has the house keys. You can get them from him by saying "PHONG, GIVE ME THE HOUSE KEYS."

Monica This mystery-loving electronics wizard was ruled by the iron hand of her father.

Stiles This frightened "friend" of the late Mrs. Linder was framed by the Linder household.

Duffy Your faithful Sergeant does all your leg-work. He is always around when not running an errand for you.

Linder This tyrant with a thing for revenge ends up being caught in his own trap.

Asta Monica's overfed cat has only a bit part.

General Hints

Before you can arrest a suspect, you must be able to prove a motive, ample opportunity, and lack of an alibi. If you arrest a suspect without proper evidence, he (or she) may get away with murder!

Every time you find a new piece of evidence, be sure to examine and analyze it.

Room Notes

1. **Driveway entrance**—There is nothing important here.

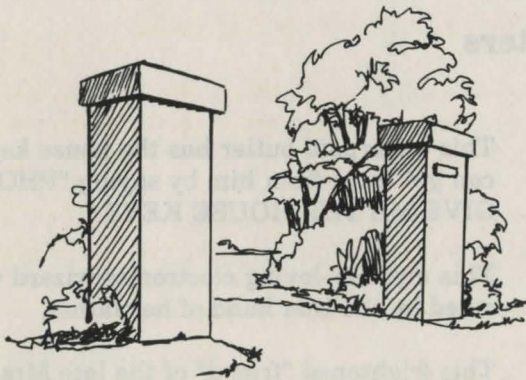

2. **Side yard**—There is nothing important here.
3. **Office path**—A muddy handgun 'appears' after the murder. Analyze it for some evidence against the murderer.
4. **Office porch**—Some footprints 'appear' after the murder. Make a cast of them and compare the cast to Stiles' shoes.



5. **Back yard**—There is nothing important here.
6. **Rock garden**—There is nothing important here.
7. **Driveway**—There is nothing important here.
8. **Front porch**—Ring the bell to get in.
9. **Garage**—Neither the Bentley, the convertible, nor the ticket stub which Monica drops on the floor when she returns is important.
10. **Workshop**—This is the place that controls the burglar alarm, the butler's button and the clock mechanism.
11. **Hallway**—There is nothing important here.
12. **Storage closet**—The broom has no use. Leave it where it is.

13. Office—When you are told to sit, sit and stay there until after the murder. Then, look at the clock, look at the keyhole, look at the powder, show the powder to Monica to put her on edge. Accuse Monica, then go to room #17 to get the medical report. Look at the desk in room #17 carefully to find the report and read it. Return to this room and push the butler's button and ask Phong about the button. Look at the window. After Monica has returned and sobbed in her bed awhile, she will come to this room. Follow her here and handcuff her to the lounge. Search her twice, and ask her about the hidden handgun. You can now arrest her.

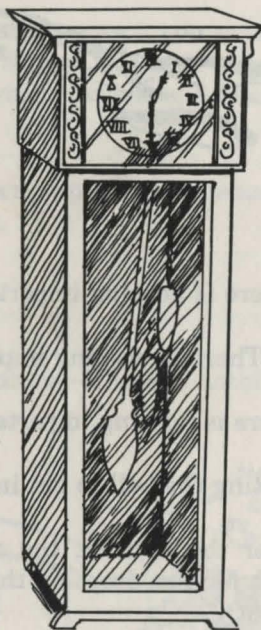

14. Hallway—There is nothing important here.

15. Entry—There is nothing important here.

16. Hallway—There is nothing important here.

17. Monica's Bedroom—On the desk is a medical report. Monica will refer to that if you accuse her after she admits to having tried to scare Stiles. For instructions on what to do with it, read the instructions for room #13. Nothing else here is important.

18. Bathroom—There is nothing important here.

19. Toilet—Monica runs in here to throw up after she sees Linder dead.



20. Tub—There is nothing important here.

21. Butler's Bedroom—Open the book on the table. Read the receipt. Ask Phong about it and he will tell you that Monica bought them. The other gun is hidden in the clock. To get it, read the instructions for room #13.

22. Bathroom—There is nothing important here.

23. Hallway—There is nothing important here.

24. Living room—When you get here for the first time, wait awhile. Stiles will be handcuffed here after Duffy gets him.

Show Stiles the threatening note. Compare the plaster cast to his shoes. Ask him about the matchbook. Ask him about the explosion. Nothing else here is important.

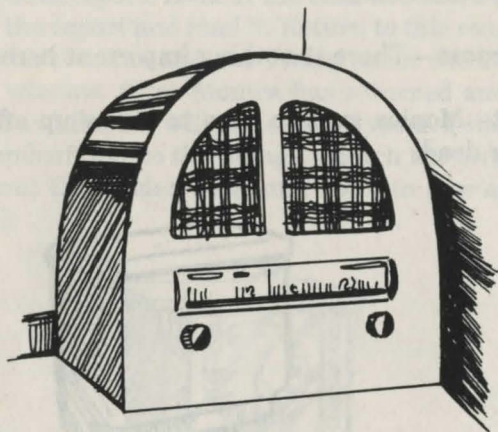

25. **Dining room**—There is nothing important here.
26. **Kitchen**—Nothing of importance is here, but Phong can usually be found here.
27. **Linders bedroom**—There is nothing important here.
28. **Front yard**—There is nothing important here.

How to Win

- Go north up to room #8, and ring the bell.
- Wait for Phong to lead you up to the living room (room #24).
- Ask Monica about Mr. Linder.
- Wait around until Linder finishes his drink.
- Sit on the wooden chair when you get to the office (room #13).
- Stay there until Linder gets killed.

- Push the office button.
- Ask Phong about the office button to get him to admit to the conspiracy.
- Look at the clock.
- Look at the keyhole.
- Get the powder.
- Analyze the powder.
- Go up to room #26 to get Phong.
- Get the house keys from him.
- Go to room #21 and open the book.
- Read the receipt.
- Go back to room #13.
- Unlock and open the back door.
- Go east.
- Make a cast of the footprints in room #4.
- Go south.
- Analyze the gun in room #3.
- Go to room #24 and compare the cast to Stiles' shoes.
- Confront Monica in the workshop (room #10) right after she returns.
- Show her the powder to get her to confess to the conspiracy.
- Accuse her.
- Go to room #17 and look at the desk carefully.
- Read the report.
- Ask Monica about the report when she goes to her room (room #17) wait until she goes out of her room again, and then follow her to room #13.
- Handcuff her.
- Search her twice.
- Ask her about the hidden handgun.
- Ask her about the clock key.
- Arrest her.
- You have now won *The Witness!*

The Witness

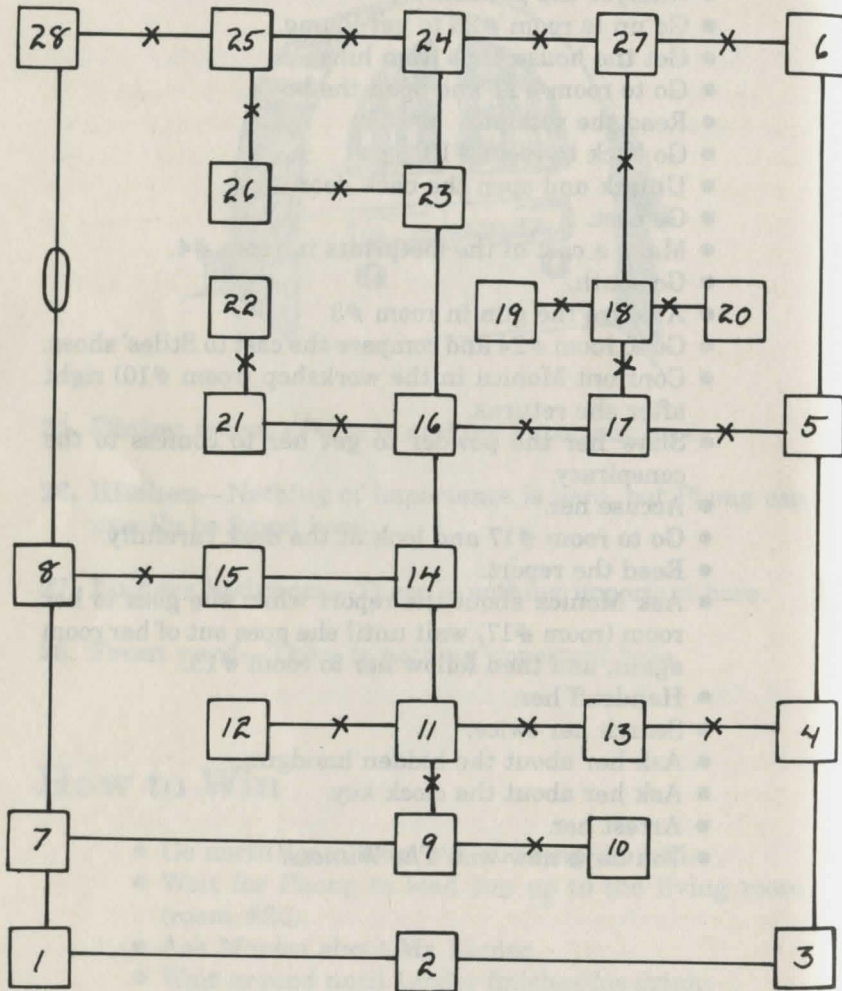

Infidel

Introduction to Infidel

To win *Infidel*, you have to find the pyramid and ransack its interior, which contains marvelous treasures. When the game starts, you are on an archeological expedition, but all the workers have drugged you and abandoned the site. You'll have to do it all yourself. When you finally open the sarcophagus, you will have won the game. *Infidel* is not related to any of the other Infocom games; it may be the beginning of a new series.

If you are trying the game for the first time, you will need the map that came with the game. It includes latitude and longitude for various locations. These will help you locate the hidden pyramid—if you have a device such as a navigation box to tell you where you are.

This marvelous piece of instrumentation will allow you to tell your latitude and longitude at the push of a button. All of the workers have drugged you and left, but the box finally comes. The box will land wherever you are if you are outside at the time. Otherwise, it will land in room #12.

General Hints

You can die of hunger or thirst in the desert if you do not have food and water with you. The only place to get food is in your tent; the only place to get water is in the Nile. Make sure you don't get eaten by a crocodile.

You will need a light source once you have found the pyramid. There will be a torch, but make sure you don't drop it on any-

thing flammable, such as the barge. It will go up in smoke, along with you.

You will find a ring on a skeleton in your quest. Do not wear it, as it is deadly.

Don't go down the steep staircase without some aid, such as a rope. You could die without the aid.

Be cautious with the beam. You'll need it in several places to get treasures without dying.

Room Notes

1. **Your tent**—The trunk can be opened by hitting the lock with the shovel (room #6), the axe (room #6), or the blackened rock (room #10). Inside the trunk is a useless inspection sticker, a map, and some bully beef. Keep the beef for when you are hungry. When you eat it, you will get thirsty. The map itself is useless, but if you unfold it, you will find a cube. The cube is important, and is used in room #22.

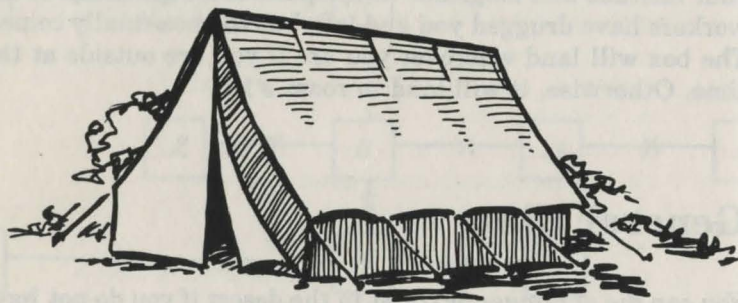

2. **Outside your tent**—Nothing is important here.
3. **Near the Nile**—Nothing is important here.



4. **River bank**—This is the only place to get water. You need water every time you get thirsty, but there are a few times that you will always need water. The first time is at the beginning of the game. The second time is right after you eat the bully beef (room #1); the third time you should have water in the canteen (room #9) is in room #75.
5. **Outside supply tent**—Nothing is important here.
6. **Supply tent**—The axe can be used in room #1, and is needed in rooms #66, #68, and #73. The shovel is needed in room #22, and can also be used in room #1.
7. **Southern path**—Nothing is important here.
8. **Outside work tent**—Nothing is important here.
9. **Work tent**—The note is useless. The knapsack is useful. Inside the sack are rope and a canteen. The canteen should be used to carry the water from room #4 around with you, and the rope is needed in room #23. Since the sack is so large, it makes a good carrier for your things, such as treasures.
10. **Fire pit**—The foil is an empty Camels cigarettes wrapper which is useless. The matchbook is needed in room #23. There are only 19 matches, so use them wisely. There is a blackened rock here. It can be used in room #1, but otherwise it has no use.



11. **Northern path**—Nothing is important here.
12. **Middle path**—Nothing is important here.
13. **Southern path**—Nothing is important here.
14. **Desert**—Nothing is important here.
15. **Desert**—Nothing is important here.
16. **Desert**—Nothing is important here.
17. **Desert**—Nothing is important here.



18. **Desert**—Nothing is important here.
19. **Desert**—Nothing is important here.
20. **Desert**—Nothing is important here.
21. **Desert**—Nothing is important here.
22. **Desert**—According to the navigation box (see introduction), this spot is at the same point as the 'X' on the map which came with the game. Dig here five times. On any other spot, you would die. Here you don't. The tip of the pyramid has a square. Put the cube from room #1 in the square. You can now go into the pyramid.

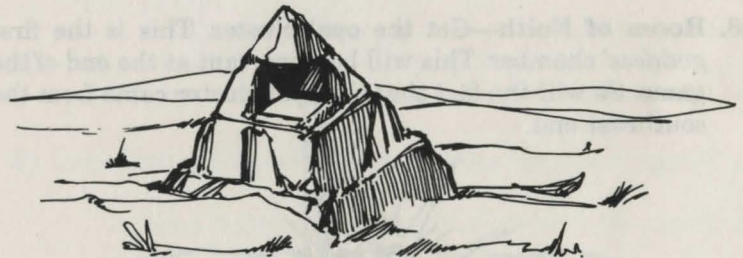

23. **Chamber of Ra**—The torch is a very good light source. However, if you get a match and try to light it, it is too dry. The stuff inside the jar is oil. Pour the oil on the torch. Now get a match, and light the torch. You can now see in other places. The stairway to the north is steep. So steep, in fact, that you cannot go down it normally. You must tie the rope from room #9 to the altar, and then go north.

24. **Circular room**—The statue is important. It is needed to get to rooms #26, #28, #30, and #32. To get to room #32, push the statue into room #27. Now come back here. Get the head that broke, and bring it in here, and drop it. You can now go to room #32. Repeat this with each spoke; for room #26, push it into room #29, for room #28, push it into room #31, and for room #30, push it into room #25. You must also drop the head in the spot where you pushed the statue. Get the golden cluster.
25. **Northeast hallway**—See the description of room #24.
26. **Room of Selkis**—Get the ruby cluster. This is the second *goddess'* chamber. This will be important at the end of the game. So will the fact that the ruby cluster came from the northeast end.
27. **Southeast hallway**—See the description of room #24.
28. **Room of Neith**—Get the opal cluster. This is the first *goddess'* chamber. This will be important at the end of the game. So will the fact that the opal cluster came from the southeast end.

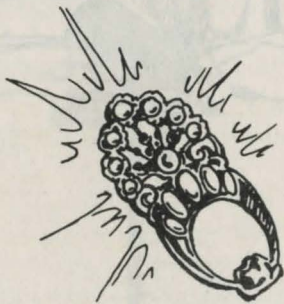

29. **Southwest hallway**—See the description of room #24.
30. **Room of Isis**—Get the emerald cluster. This is the third *goddess'* chamber. This will be important at the end of the game. So will the fact that the emerald cluster came from the southwest end.

31. **Northwest hallway**—See the description of room #24.
32. **Room of Nephthys**—Get the diamond cluster. This is the fourth *goddess'* chamber. This will be important at the end of the game. So will the fact that the diamond cluster came from the northwest end.
33. **South landing**—Nothing is important here.
34. **Narrow hallway**—Nothing is important here.
35. **Narrow hallway**—Nothing is important here.
36. **Barge chamber**—Nothing is important here.
37. **Center of barge**—The mast will be here if you have lifted it. If you haven't, you should. Go down to room #41 and do it.

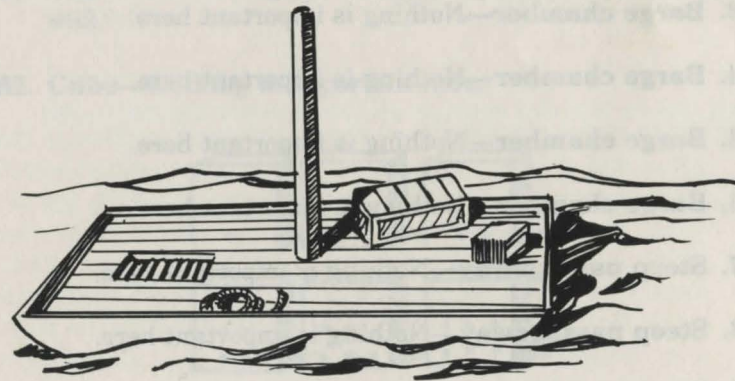

38. **Fore cabin**—The scroll tells you what to do in room #63.
39. **Aft cabin**—Nothing is important here.
40. **Below deck**—Nothing is important here.

41. **West end of hold**—Put the torch in the knothole; you're going to need your hands free. Get the shim which is holding the beam down. Drop everything. Lift the beam. Get everything but the shim. Be sure you have the torch. Go up to room #37 and get the beam; it is needed in rooms #68, #71, and #73.

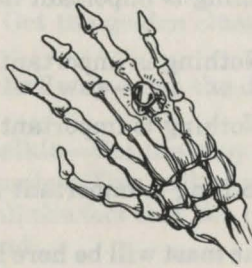

42. **Barge chamber**—Nothing is important here.
43. **Barge chamber**—Nothing is important here.
44. **Barge chamber**—Nothing is important here.
45. **Barge chamber**—Nothing is important here.
46. **Barge chamber**—Nothing is important here.
47. **Steep passageway**—Nothing is important here.
48. **Steep passageway**—Nothing is important here.
49. **Steep passageway**—Nothing is important here.
50. **Temple chamber**—Nothing is important here.
51. **Inner chamber**—The skeleton is useless. The glittering thing is a ring. The ring has a use. It is a trap for greedy adventurers. Don't wear it or you will die. Don't bother getting it, because it isn't worth any points.

52. **Golden chamber**—Nothing is important here.
53. **Golden alcove**—Get the golden chalice; it is needed in room #75.
54. **Silver chamber**—Nothing is important here.
55. **Silver alcove**—Get the silver chalice; it is needed in room #75.
56. **Cube**—Nothing is important here.
57. **Cube**—Nothing is important here.
58. **Cube**—Nothing is important here.
59. **Cube**—Nothing is important here.
60. **Cube**—Nothing is important here.
61. **Cube**—The hieroglyphics also tell you what to do in room #63.
62. **Cube**—Nothing is important here.

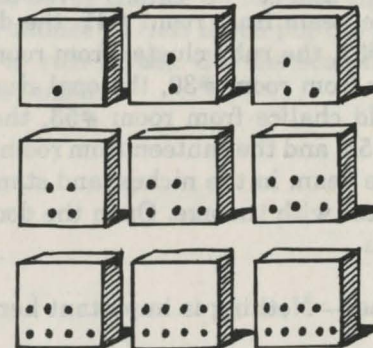

63. **Cube**—Get the first, third, and fifth bricks, as instructed by the scroll in room #38 and the hieroglyphics in room #61.

64. **Turning passage**—Nothing is important here.
65. **Top of stairway**—Nothing is important here.
66. **Bottom of stairs**—To get the door open, hit the plaster with the axe from room #6.
67. **Narrow passageway**—Nothing is important here.
68. **Narrow passageway**—Nothing is important here.

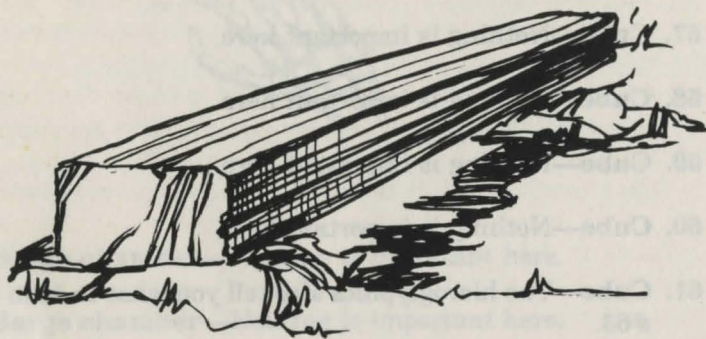

69. **Narrow passageway**—Before continuing, make sure that you have the beam from room #41, the diamond cluster from room #32, the ruby cluster from room #26, the emerald cluster from room #30, the opal cluster from room #28, the gold chalice from room #53, the silver chalice from room #55, and the canteen from room #9, with water in it. Put the beam in the niches, and stand on the beam. Hit the plaster with the axe. Open the door. Go west and get the beam.
70. **Antechamber**—Nothing is important here.
71. **Antechamber**—Come here before going to room #74. Put the beam between the rocks and open the door. Go west. When you come back out, get the beam; you will need it in room #73.

72. **Annex**—If you followed the directions in room #69, you should have all the clusters. Put the diamond cluster in the first hole, the ruby cluster in the second hole, the emerald cluster in the third hole, and the opal cluster in the fourth hole. Lift the slab, and get the book. It is needed in room #74. The only way to read the book is to get the spatula and open the book using the spatula, but it isn't necessary.
73. **Antechamber**—Before continuing, make sure that you have been to room #72 and have followed those directions. Put the beam under the lintel. Hit the seals with the axe. Open the door. Go to room #75, then to room #74.
74. **Burial chamber**—Before following the directions here, go to room #75, and follow those directions. If you are here, you should have the book from room #72 and the scarab from room #75. Put the book in the large recess and the scarab in the small recess. Turn the goddesses in the order of their rooms. In other words, turn Neith, turn Selkis, turn Isis, and turn Nephthys. You can now open the sarcophagus and win.
75. **Treasury**—Put the gold chalice on either the right or left disc. Pour the water from the canteen into the silver chalice. Put the silver chalice on the disc that you didn't put the golden chalice on (left if you put the golden chalice on the right, or vice versa). Get the scarab, and go to room #74 to win *Infidel*.

How to Win

- Get up.
- Go to room #6.
- Get the axe and the shovel.
- Go to room #10.
- Get the matchbook.
- Go to room #9.
- Get the knapsack.
- Go to room #1.
- Hit the lock with the axe or the shovel.
- Get the lock.
- Drop the lock.
- Open the trunk.
- Get the beef and the map.
- Unfold the map.
- Get the cube.
- Drop the map.
- Go to room #4.
- Drink the water four times.
- Drop the knapsack.
- Get the canteen.
- Open the canteen.
- Fill the canteen.
- Close the canteen.
- Put the canteen in the knapsack.
- Eat the beef.
- Get the knapsack.
- Go to room #22.
- Dig the sand with the shovel five times.
- Drop the shovel.
- Put the cube in the square.
- Go to room #23.
- Get the jar.
- Open the jar.
- Get the torch.
- Pour the liquid on the torch.
- Get a match.
- Light the match.
- Light the torch.
- Drop the knapsack.

- Get the rope.
- Put the matchbook in sack.
- Tie the rope to the altar.
- Throw the rope down the steep staircase.
- Get the knapsack.
- Go to room #24.
- Drop the knapsack.
- Put the golden cluster in the knapsack.
- Push the statue northwest.
- Get the head.
- Push the statue northwest.
- Drop the head.
- Go to room #28.
- Get the opal cluster.
- Go to room #24.
- Put the opal cluster in the knapsack.
- Go to room #31.
- Get the head.
- Push the statue southeast.
- Push the statue southeast.
- Drop the head.
- Go to room #32.
- Get the diamond cluster.
- Go to room #24.
- Put the diamond cluster in the knapsack.
- Go to room #27.
- Get the head.
- Push the statue northwest.
- Push the statue northeast.
- Drop the head.
- Go to room #30.
- Get the emerald cluster.
- Go to room #24.
- Put the emerald cluster in the knapsack.
- Go to room #25.
- Get the head.
- Push the statue southwest.
- Push the statue southwest.
- Drop the head.
- Go to room #26.
- Get the ruby cluster.

- Go to room #24.
- Put the ruby cluster in the knapsack.
- Get the knapsack.
- Go to room #51.
- Drop the knapsack.
- Go to room #53.
- Get the golden chalice.
- Go to room #51.
- Put the golden chalice in the knapsack.
- Go to room #55.
- Get the silver chalice.
- Go to room #51.
- Put the silver chalice in the knapsack.
- Get the knapsack.
- Go to room #41.
- Put the torch in the knothole.
- Get the shim.
- Drop all.
- Lift the beam.
- Get the torch, knapsack, axe, jar.
- Go to room #37.
- Get the beam.
- Go to room #63.
- Get the first, third, and fifth bricks.
- Drop all bricks.
- Go to room #66.
- Hit the plaster with the axe.
- Go to room #69.
- Put the beam in the niches.
- Stand on the beam.
- Hit the plaster with the axe.
- Open the door.
- Go to room #70.
- Pour the oil on the torch.
- Get the beam.
- Go to room #71.
- Put the beam between the rocks.
- Open the door.
- Go to room #72.
- Drop the knapsack.
- Put the diamond cluster in the first hole.

- Put the ruby cluster in the second hole.
- Put the emerald cluster in the third hole.
- Put the opal cluster in the fourth hole.
- Lift the slab.
- Get the book, knapsack.
- Go to room #71.
- Get the beam.
- Go to room #73.
- Put the beam under the lintel.
- Hit the seals with the axe.
- Open the door.
- Go to room #75.
- Drop the knapsack.
- Put the gold chalice on the left disc.
- Get the canteen, silver chalice.
- Open the canteen.
- Pour the water into the silver chalice.
- Put the silver chalice on the right disc.
- Get the scarab.
- Go to room #74.
- Put the book in the large recess.
- Put the scarab in the small recess.
- Turn Neith.
- Turn Selkis.
- Turn Isis.
- Turn Nephthys.
- Open the sarcophagus.
- You have now won *Infidel*.

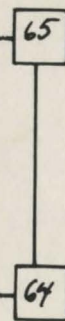
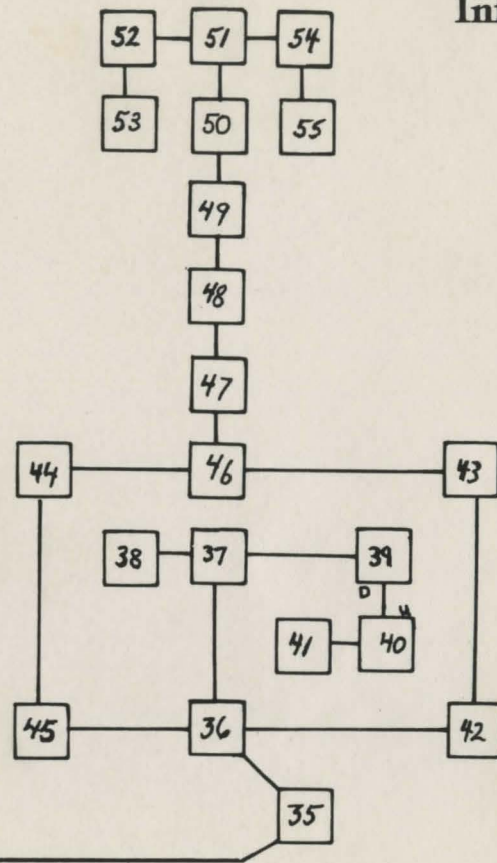
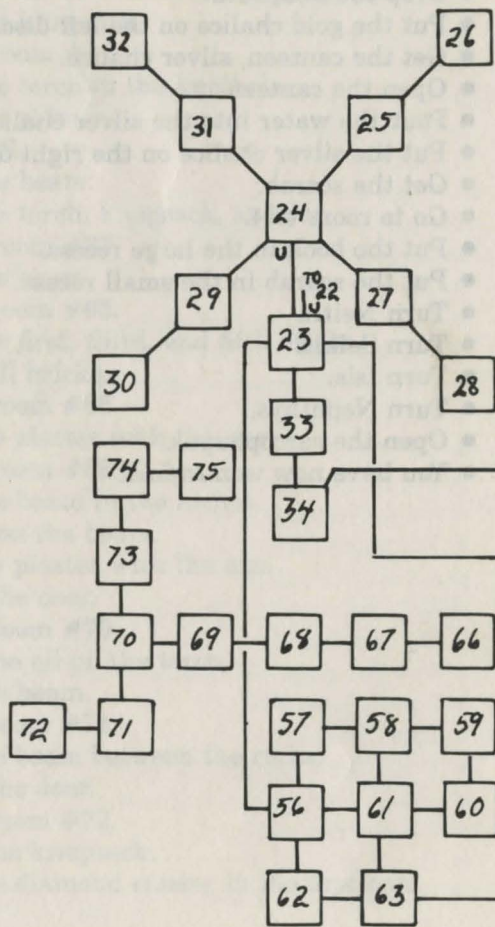
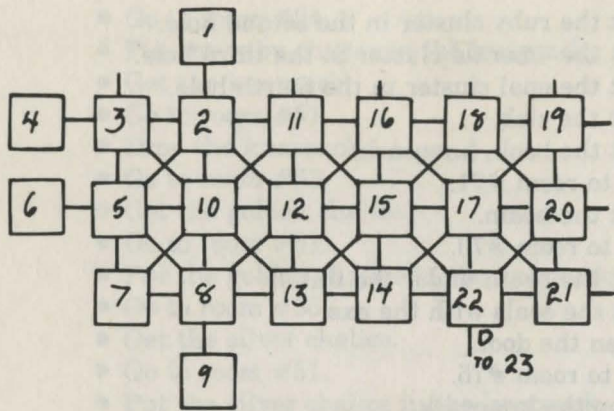

Index

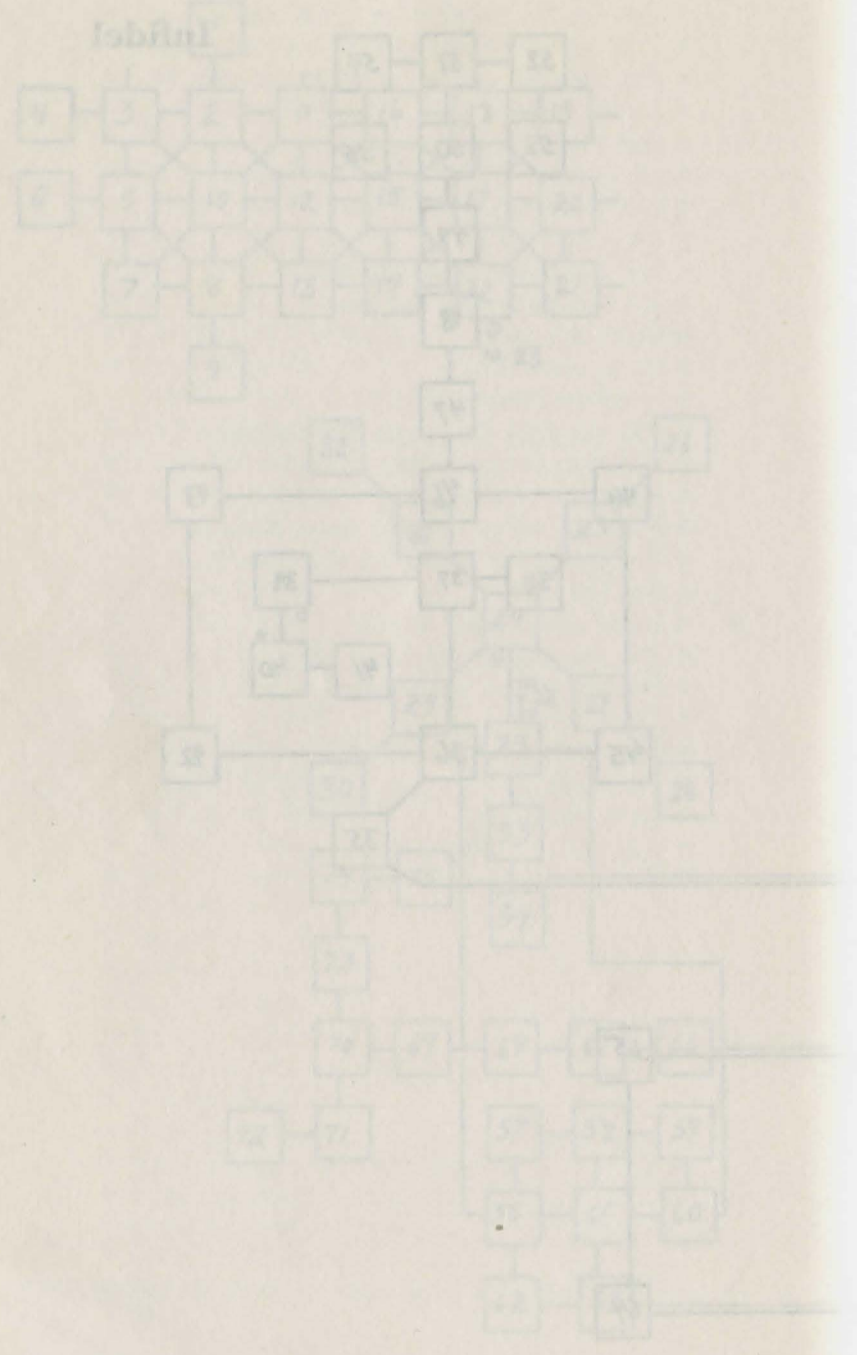

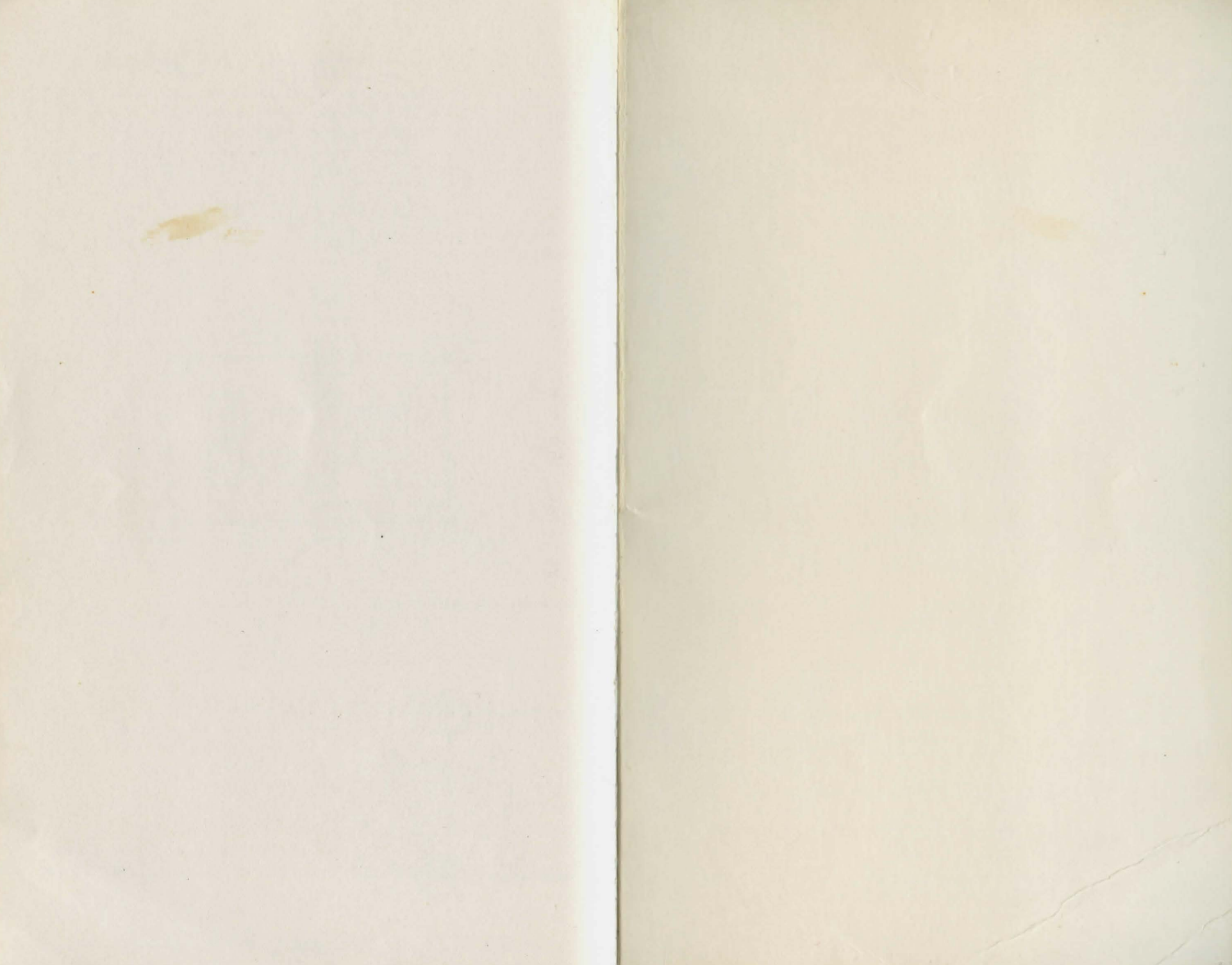

A Shortcut Through Adventureland

VOL. II - INFOCOM

Feeling frustrated? Stuck? Can't seem to move beyond a certain point in your favorite Infocom Adventure? RELAX — here's the solution!

A SHORTCUT THROUGH ADVENTURELAND VOL. II - INFOCOM contains the answers to ALL the Infocom Adventures published to date — the Zork Trilogy, Enchanter, Deadline, The Witness, Infidel, Suspended, Planetfall, and Starcross. Packed with hints and maps, this revealing book will add years to your life and stop frustration before it starts!



ISBN 0-88190-358-2

 **DATAMOST**
INC. ®

20660 Nordhoff Street, Chatsworth, CA 91311-6152 (818) 709-1202